

bintec RSC Router

Installation Manual

Copyright© bintec Dm567-I Version 9.5 02/2020 bintec elmeg

Legal Notice

Warranty

This publication is subject to change.

bintec elmeg offers no warranty whatsoever for information contained in this manual.

bintec elmeg is not liable for any direct, indirect, collateral, consequential or any other damage connected to the delivery, supply or use of this manual.

Table of Contents

Chapter 1	About This Manual	1
1.1	Supported Devices	1
1.2	Who should read this manual?	1
1.3	When should this manual be read?	1
1.4	What is in this manual?	1
1.5	What is not in this manual?	1
1.6	How is the information organized?	1
1.7	Technical Support	1
1.8	Related Documentation	2
Chapter 2	bintec RSC Router	3
2.1	Features.	3
2.1.1	Power supply	3
2.1.2	Hardware Monitoring	3
Chapter 3	Components and Power Supply	4
3.1	Components	4
3.1.1	Front Panel	4
3.1.2	Rear Panel	4
3.1.3	Side Panels	5
3.1.4	Underside Panel	5
3.1.5	Top Panel (LEDs).	6
3.2	Mounting in rack	7
3.2.1	Standalone	8
3.2.2	Wall mounting	8
3.3	Plug-in Modules	10
3.3.1	Installation.	10
3.3.2	Removal.	10
3.4	Power Source	10
3.4.1	External Power Source	10
3.4.2	Connecting	11
3.4.3	Disconnect.	11
3.5	RST Button	11
3.5.1	Rebooting the device	11
3.5.2	Default Configuration	11
3.6	Connecting the data.	12
3.6.1	4-port Ethernet Switch.	12

3.6.2	WAN Connection	12
3.6.3	DSL Connection	12
3.6.4	WWAN Antenna Connection (Cell connector).	14
3.6.5	Wireless LAN Antenna Connection (Wi-Fi connectors).	15
3.6.6	Connecting a 3G USB device (USB connector)	15
3.7	Installing the SIM card.	16
Chapter 4	Compliance	17
4.1	Manufacturer Information	17
4.2	Safety Warnings	17
4.3	WEEE Information	21
4.4	REACH	21
4.5	China RoHS	21
4.6	PSU Energy Efficiency	22
4.7	EC Declaration of Conformity.	23
4.8	CE Marking	23
4.9	National Restrictions	24
4.10	Operating Frequency	24
4.11	FCC Statement.	24
4.11.1	Federal Communications Commission Interference	24
4.11.2	FCC Radiation Exposure Statement.	24
4.11.3	FCC Part 68 Notice	25
4.12	IC Statement.	25
4.12.1	CAN ICES-3 (B)/NMB-3(B).	25
4.12.2	IC Radiation Exposure Statement.	26
4.12.3	For Industry Canada only	26
4.12.4	IC Notice	26
Appendix A	Technical Information.	28
A.1	Troubleshooting	28
A.2	Updating the software	28
A.3	Connectors	29
A.3.1	LAN Connector.	29
A.3.2	WAN Connector	29
A.3.3	WWAN/Cell Connector (female)	29
A.3.4	WLAN/WiFi Connector (male)	30
A.3.5	DSL Connector.	30
A.3.6	USB Connector.	30
A.3.7	Configuration Connector.	30

A.3.8	Power Supply Connector	31
A.4	Technical Specifications	31
A.4.1	Hardware Architecture.	31
A.4.2	LAN Interface	31
A.4.3	WAN Interface	31
A.4.4	DSL Interface	31
A.4.5	Wireless WAN Interface	32
A.4.6	Wireless LAN Interface	32
A.4.7	USB Interface	32
A.4.8	Configuration Interface	32
A.4.9	Power Supply	32
A.4.10	External Power Supply	33
A.4.11	Dimensions and weight	33
A.4.12	Environmental Specifications.	33
Appendix B	Radio Information.	34
B.1	RF LTE Specifications.	34
B.2	RF GSM/WCDMA Specifications	34
B.3	WI-FI Specifications.	35

Chapter 1 About This Manual

This is the installation manual for the **bintec RSC** router and contains information on how to correctly install the device in a working environment.

1.1 Supported Devices

The information provided in this installation manual only applies to the **bintec RSC** router

1.2 Who should read this manual?

This manual should be read by the support personnel who need to install, configure, maintain and monitor the device.

1.3 When should this manual be read?

Read this guide as soon as you are ready to familiarize yourself with the device and its components.

This manual will help you understand your new device in greater depth.

1.4 What is in this manual?

This installation guide contains the following information:

- A description of the features that are available in the **bintec RSC**.
- Technical specifications.
- Power supply requirements.
- Elements you can connect to the device while it is running.
- Installation and removal procedures for modules and power supplies.
- A description of the device LEDs and connectors.
- Troubleshooting.

1.5 What is not in this manual?

This manual does not contain information on the device software or its configuration. For information on how to configure this device, please see the relevant protocol manuals at the bintec elmeg website: <http://www.bintec-elmeg.com>

1.6 How is the information organized?

Each chapter focuses on a specific part of the hardware and its components. All descriptive and technical specifications on a component can be found in the relevant chapter.

1.7 Technical Support

bintec elmeg offers technical support. Device software can be upgraded on a regular basis for maintenance purposes and for new features.

Contact information:

Web: <http://www.bintec-elmeg.com>

Tel. N°: +49 - 911 - 9673 0

Fax: +49 - 911 - 688 0725

Email: support@bintec-elmeg.com

1.8 Related Documentation

bintec Dm741-I *ADSL- VDSL2*

bintec Dm748-I *Software Updating*

bintec Dm781-I *Cellular Interface*

Chapter 2 bintec RSC Router

2.1 Features

2.1.1 Power supply

For further information on the **bintec RSC** router power supply, please see [Components and Power Supply](#) on page 4 , under section [Power Source](#) on page 10.

2.1.2 Hardware Monitoring

The only way to monitor the **bintec RSC** router hardware is through the LED panel. LEDs provide visual information on the state of the device, indicating the state of hardware components, whether there is connectivity or not, information on data flows, etc.

For further information on the LED panel, please see [Components](#) on page 4.

Chapter 3 Components and Power Supply

The following chapter provides detailed information on the chassis of the **bintec RSC** router and its components. This information includes:

- Components.
- Information on assembly.
- Installation and removal of modules.
- Power supply.
- RST button.
- Data connection.
- SIM card installation.

3.1 Components

3.1.1 Front Panel

The following figure shows the front panel. The only thing to be found here are the 3G antenna connectors.

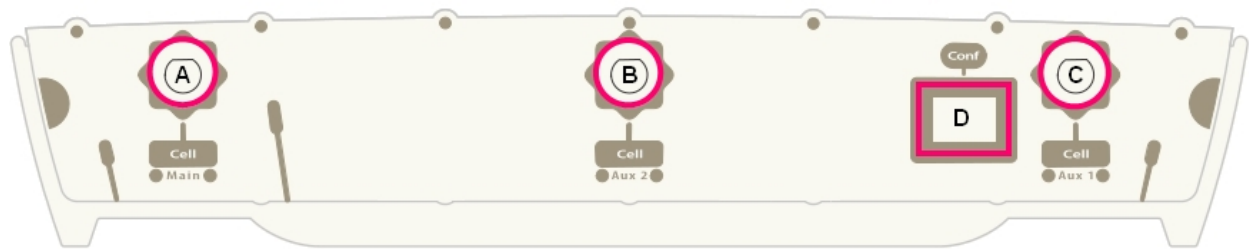

Fig. 1: Front Panel

The front panel elements are as follows:

Front Panel Elements

Item	Description
A	Main antenna for the bintec RSC cellular module.
B	Auxiliary antenna 2 for the bintec RSC cellular module.
C	Auxiliary antenna 1 for the bintec RSC cellular module.
D	RJ-45 connector, which provides access to the bintec RSC local console for configuring and monitoring purposes.

3.1.2 Rear Panel

The following figure shows the rear panel. Here you can see the rest of connectors for the **bintec RSC** router.

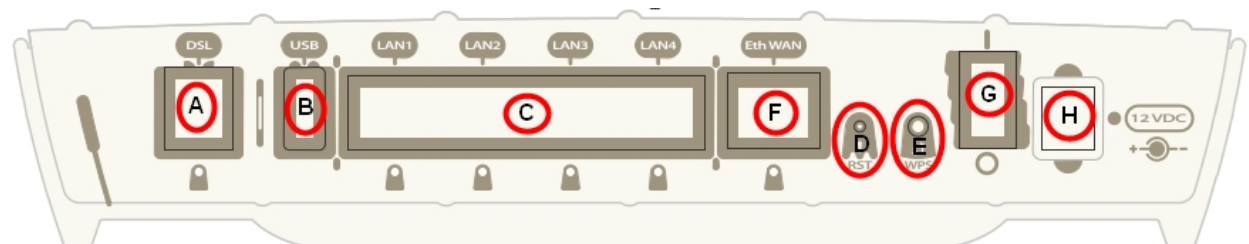

Fig. 2: Rear Panel

The following table provides information on each connector, as well as a description:

Rear panel elements

Item	Description
A	DSL. DSL connector.
B	USB. Slot where you can insert a 3G USB modem.
C	4-port Gigabit Ethernet Switch.
D	RST. Reset button. For further information on how the reset button works, please see RST Button on page 11
E	WPS (Wireless Protected Setup). This enables Wi-Fi network parameters to be configured easily and in a safe manner.
F	Eth WAN. WAN Gigabit Ethernet.
G	On/Off switch.
H	Power source connection (PSU).



Note

The WPS system is not currently included, but it will be available for future software versions.

3.1.3 Side Panels

Two Wi-Fi antennas are located on the side panels, one on either side.



Fig. 3: Right hand side panel and Fig. 4: Left hand side panel

3.1.4 Underside Panel

The following elements can be found on the underside panel:

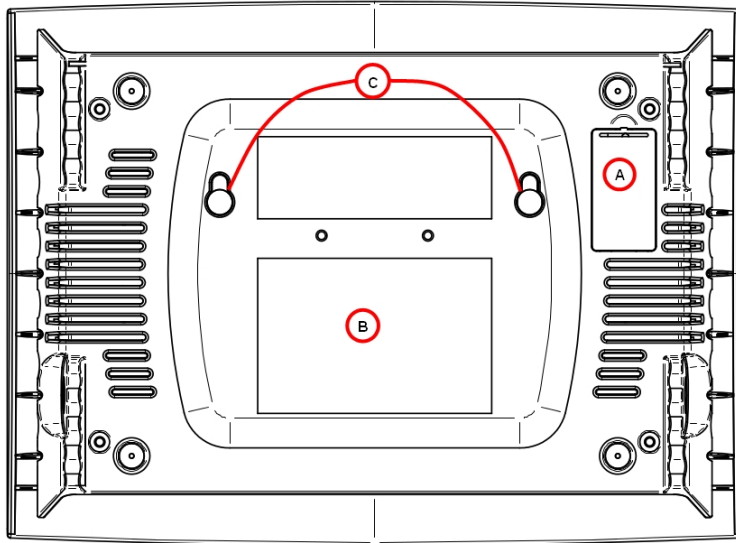

Fig. 4: Underside Panel

The following table contains details on the elements located on the underside panel.

Underside panel elements table

Item	Description
A	SIM tray for the 3G internal module. This is accessed from the bottom of the router.
B	Platform where the label containing the product information is located. This label contains information on the device model, mac, serial number, etc.
C	Wall mounting slots.

3.1.5 Top Panel (LEDs)

The LED panel provides information on the status of the components (whether they are active or not) and on network activity.

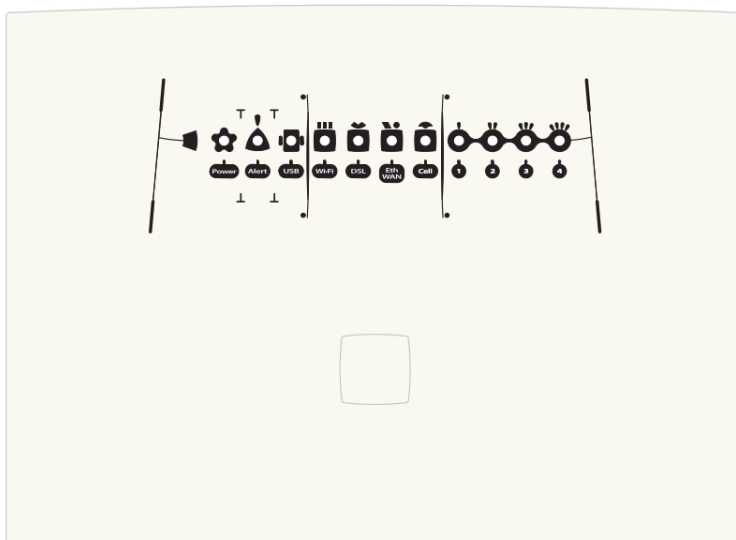

Fig. 5: LED panel

The **bintec RSC** router LEDs are shown in the above figure. The table below contains a description of each.

LED table

LED	Status	Description
Power	Monochrome	Off -> not being powered through PSU.
	Green	On -> powered through PSU.
Alert	Monochrome Green	On -> when software is running.
USB	Tricolor	Off -> system is powered off.
		<p>Red -> interface is unavailable because it is installing, disabled (shutdown) or due to auto-test failure.</p> <p>Amber -> idle.</p> <ul style="list-style-type: none"> • Rapid blinking. It hasn't registered in the network or the quality is insufficient. • Slow blinking. GSM connection (GPRS). • Steady. WCDMA (UMTS / HSDPA) connection. <p>Green -> connected. Blinking: connection data activity.</p>
Wi-Fi	Bicolor	Red -> interface down.
		<p>Green -> interface up.</p> <p>Blinking (green/red) -> activity/maintenance.</p>
DSL	Monochrome	Slow blinking -> not connected.
	Green	<p>Rapid blinking -> the link is being established.</p> <p>Steady -> connected.</p>
Eth WAN	Tricolor	Green -> connected. Blinking: connection data activity.
		<p>Amber -> blinking, auto-test.</p> <p>Red -> disconnected.</p>
Cell	Tricolor	Off -> system is powered off.
		<p>Red -> interface is unavailable because it is installing, disabled (shutdown) or due to auto-test failure.</p> <p>Amber -> idle.</p> <ul style="list-style-type: none"> • Rapid blinking. It hasn't registered in the network or the quality is insufficient. • Slow blinking. GSM connection (GPRS). • Steady. WCDMA (UMTS / HSDPA) connection. <p>Green -> connected. Blinking: connection data activity.</p>
Coverage (1, 2, 3, 4)	Monochrome blue	Indicates the coverage level the 3G internal module has. 0 level (all LEDs off) to 4 (all LEDs on).

3.2 Mounting in rack

The **bintec RSC** router cannot be mounted in a rack. However, there are other types of mounting.

3.2.1 Standalone

The **bintec RSC** router can be placed as a standalone on a flat, stable surface.

Please ensure there is enough space around the router for ventilation purposes and that the electricity cables can comfortably reach it.

3.2.2 Wall mounting

The **bintec RSC** can be mounted on the wall.

Two slots on the underside of the device can be used to fix it to the wall. You can see this in “ [Underside Panel](#) on page 5

You must purchase the screws and wall anchors. We recommend the following accessories for wall mounting, valid for both solid and plaster (Gypsum board) walls:

- 2 screws: [COACH SCREW HEAD 90 DEGR.POZIDR. 3,5x30]



Fig. 6: **Screw**

- 2 wall anchors: [WHITE STRIATED WALL ANCHOR DIAM.8mm]



Fig. 7: **Wall anchor**



Warning

The screws must go into a wall stud (wood) or a wall anchor of the appropriate type for the wall. Screws into drywall are not strong enough to hang the router.

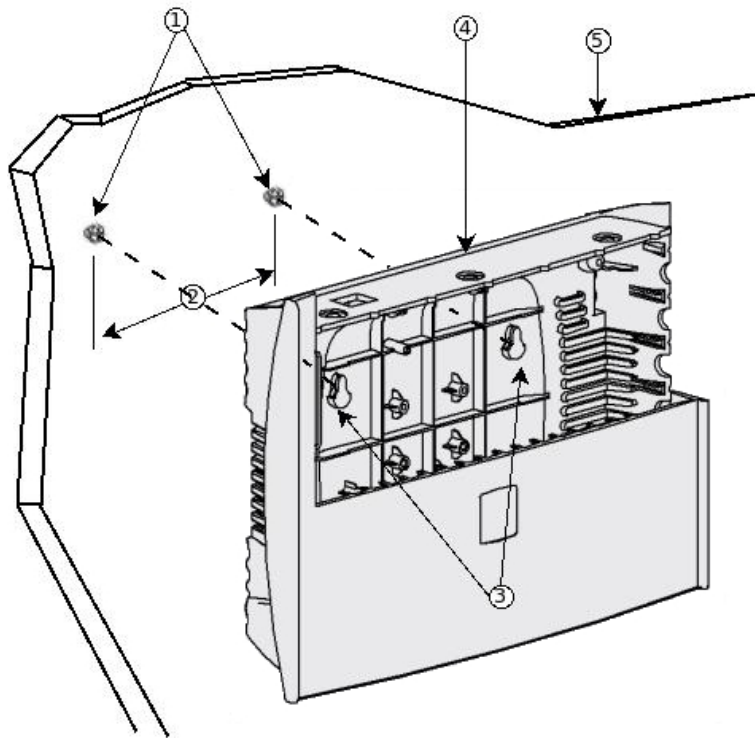

Fig. 8: Wall-mounting features on the bintec RSC router

The previous Figure shows the wall-mounting features on the **bintec RSC**.

1	Wall screws	2	10.2 cm (4.02 inches)
3	Chassis mounting holes (on bottom)	4	Router chassis
5	Mounting surface		

To install the router on a wall, or any other surface, follow these steps:

Procedure

Step 1: Place the two screws (3.5x30) on the wall, or in any other vertical surface, horizontally and apart.

The screws should protrude 0.6 cm (0.25 inches) from the surface of the wall.



Warning

If you install the screws in drywall, use hollow-wall anchors (8mm – 5/16 inch) to secure the screws. If the screws are not properly anchored, the strain of the cables connected to the router's back panel could pull the router from the wall.

Step 2: Hang the router on the screws as shown (see [Fig. 8](#) on page 9) for safety reasons.



Note

- The accessories to mount the device on a wall are not provided in the package and have to be acquired separately.
- The accessories must be appropriate for your type of wall. Make sure they can support the weight of the device.

3.3 Plug-in Modules

The only module that can be inserted in the device is the USB 3G modem. To view the list of 3G modems supported, please visit the following website: support@bintec-elmeg.com

3.3.1 Installation

To install the USB modem, simply insert it in the USB slot located on the rear panel (as shown in the following figure):

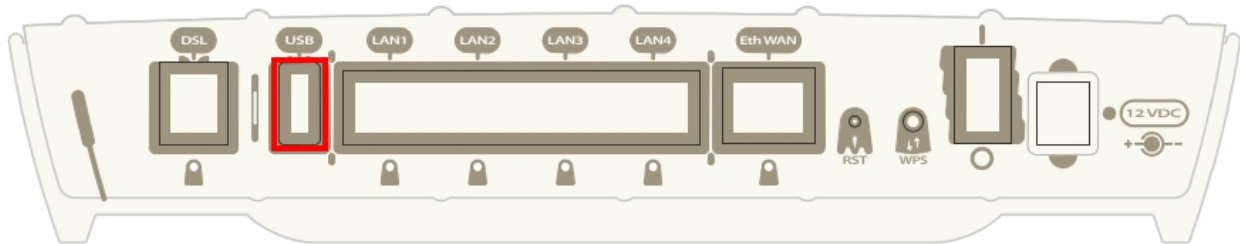

Fig. 9: USB modem insertion slot

3.3.2 Removal

To remove the device, simply remove it from the slot where it was inserted. See [Fig. 9](#) on page 10.

3.4 Power Source

The **bintec RSC** router is powered through an external AC/DC.



Warning

The equipment must be used with the power supply provided by the manufacturer.

Workplace Conditions. Main Characteristics

- Avoid humid and or dusty locations.
- Direct exposure to sunlight and other heat sources should be avoided. The device should not be placed amongst papers, magazines or other elements that could hinder natural air circulation.
- The device should not be placed very close to strong electromagnetic fields (such as speakers, engines, etc).
- Knocks and/or strong vibrations should be avoided during transport, operation and storage.



Warning

The electric current in power cables, telephone lines and communication cables is dangerous. To prevent electric shocks, before installing, handling or opening the equipment covers, connect and disconnect the cables following the steps set forth in "[Connecting](#)" on page 11 and "[Disconnect](#)" on page 11.

3.4.1 External Power Source

To connect the power supply to the device, please follow the steps set forth in "[Connecting](#)" on page 11.

To avoid electric shocks, residual current circulation and other unwanted effects, which also affect communications, we recommend the following:

**Warning**

All interconnected communication devices should be plugged to THE SAME GROUNDED POWER OUTLET, which should, at the same time, be of good quality (lower than 10 ohms).

Whether the workplace is provided with an uninterrupted power supply system (UPS), regulated supply or it is independent from the rest (such as lighting, etc.); it is highly recommended that all data devices should be connected to the same power source. This will avoid operating and premature aging problems of drivers and other components.

3.4.2 Connecting

- Make sure the router's power switch is in the OFF position (0).
- Make sure the power supply is NOT connected to either the electricity or the router.
- Connect all data cables.
- Connect the power supply cable to the device.
- Connect the power supply cable to the electricity supply.
- Set the router's power switch to the ON position (1).

3.4.3 Disconnect

- Make sure the router's power supply switch is in the OFF position (0).
- Disconnect the power supply from the electricity supply.
- Disconnect the power supply from the router.
- Disconnect the data cables.

3.5 RST Button

The different RST button features are described below.

3.5.1 Rebooting the device

Once the device is operating normally, press the RST button for it to restart.

3.5.2 Default Configuration

The RST button allows you to boot the device with its default configuration through the following steps:

- With the device switched off, keep the RST button pressed and switch on the router using the ON/OFF switch (1).
- The Power LED (green) will light up and the USB LED will begin to blink (green). Blinking will continue for 10 seconds.
- For the device to boot with the default configuration, release the RST button while the USB LED is blinking (i.e. before the 10 second period expires).

The router's default configuration establishes the following IP address and mask:

- IP address: 192.168.1.1
- IP mask: 255.255.255.0

**Note**

Some devices leave the factory with personalized settings. As a result of this customization, the default configuration can be different from the one shown above.

3.6 Connecting the data

The **bintec RSC** router has the following data connections.

3.6.1 4-port Ethernet Switch

The **bintec RSC** router incorporates a 4-port 10/100/1000 BaseT Switch with automatic MDI/MDIX to connect to a local area network (LAN).

Please pay careful attention to the labeling so you do not mix this switch with other types of ports:

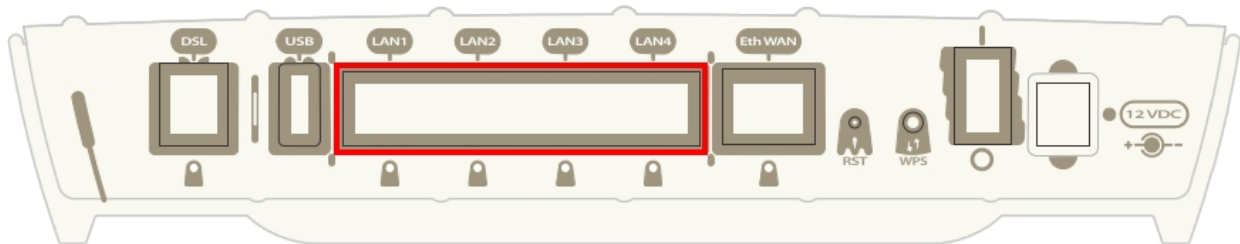

Fig. 10: LAN switch Ports



Note

During booting and in BIOS mode, only the LAN 1 connector is available.

3.6.2 WAN Connection

The **bintec RSC** incorporates an Ethernet WAN 10/100/1000 BaseT port with automatic MDI/MDIX.

The WAN port is independent from the switch and is handled as just one more interface.

Please pay careful attention to the labeling so you do not mix this switch with other types of ports:

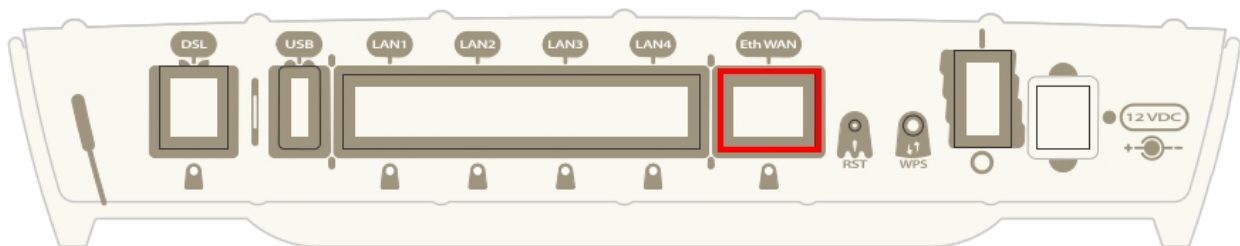

Fig. 11: WAN Port



Note

During booting and in BIOS mode, the Eth WAN connector does not work.

3.6.3 DSL Connection

The **bintec RSC** has a DSL connector to connect to a VDSL2/ADSL network. This is a 4-wire female RJ11 connector that uses the **central pair** for data transmission/reception.

For connection purposes, you can use the telephone cable with male RJ11 connectors (provided with the device).

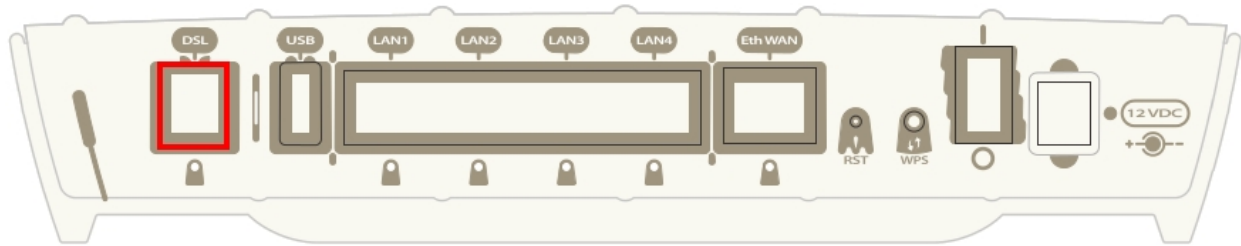

Fig. 12: DSL Port (VDSL2/ADSL)

The splitter

By default, supported modes do not allow devices that provide basic services (PSTN or ISDN, depending on the model) and are directly connected to the same line to be used. You need to use a device known as a *splitter*, which separates the basic service band frequencies from those used by the DSL connection. This ensures there is no interference between the telephone and the DSL service.

A typical installation with a splitter is shown in figure 14.

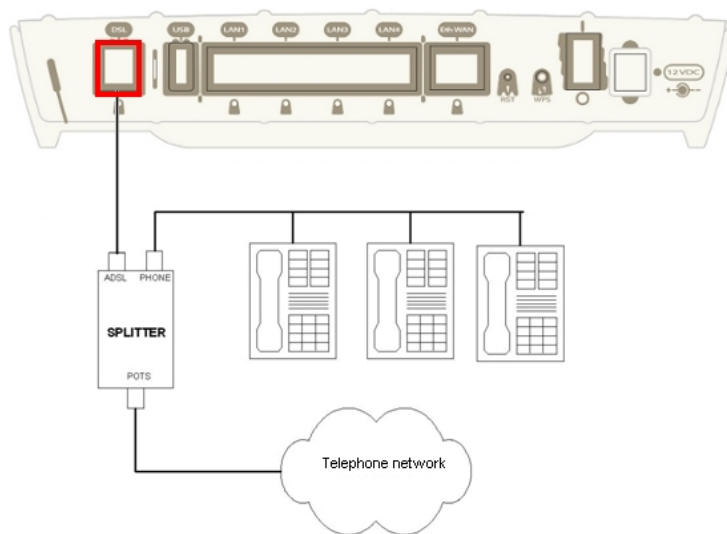

Fig. 13: ADSL Installation with splitter

The micro-filters

Only certain DSL operating modes (eg, G.Lite or ITU G.922.2) allow, with the help of a *micro-filter*, the use of some basic service devices (PSTN or ISDN) directly connected to the same line. This device ensures the DSL signal does not reach the basic service device, and that undesired signals generated by the device do not interfere with the DSL signal.

A typical installation with micro-filters is shown in figure 15.

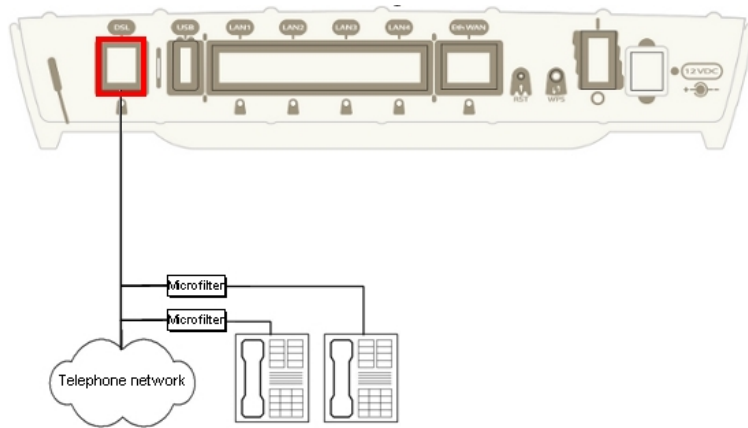

Fig. 14: ADSL Installation with Micro-filters

3.6.4 WWAN Antenna Connection (Cell connector)

The **bintec RSC** router has three connectors for 3G antennas. To assemble and disassemble the antennas, simply screw them into the connectors labeled *Cell* (located on the front panel of the router).

Installing these antennas in the **bintec RSC** router helps improve the quality of the signal received and transmitted by the cellular model.

For the Wireless WAN interface to operate, the device must have a plug-in wireless WAN card and the corresponding software license. If your device does not have an integrated wireless WAN module, you can add it later on. The manual provided will show you how to install the module and the corresponding antenna cables in the device.



Note

To achieve optimum performance, the router should always have the WWAN antennas installed.

So the *cellular* interface is operative, the router must have the corresponding software license incorporated.

Some cellular telephony technologies use the antenna diversity technique to improve the quality of the received signal (HSUPA, CDMA EV-DO, etc.). The **bintec RSC** router therefore incorporates several WWAN connectors.

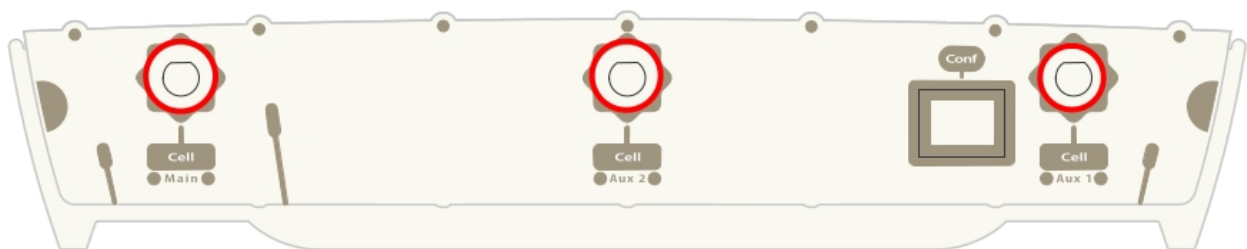

Fig. 15: WWAN antennas

When the Main and Aux 1 antennas are not directly connected to the router, but installed through extension cords, the minimum distance between the two must be 7 cm. The maximum recommended distance between them is 25 cm.

To achieve optimum performance, the radio frequency accessories installed (antennas and cables) should be those recommended by us.

We have a series of accessories (90° mount antennas, antennas for exterior installation, antennas ceiling installation, extension cables, etc.) that allow you to install the devices in different locations.

3.6.4.1 Placing the Antenna

The orientation of the antenna and its location with respect to other wireless devices or other radiation sources (such as communication devices, personal computers, etc.) can influence device performance.

The antennas transmit and receive radio signals. This performance is also affected by environmental factors (such as the distance between the device and the base station), physical obstacles and other interferences due to radio frequencies (RF).

For optimum coverage, follow these steps:

- Whenever possible, place the antenna where there are no physical obstacles. Obstacles between the antenna and the base station degrade the wireless signal. Place the antenna above ground level facing the nearest base station.
- The density of materials also affects the antennas. Place them away from all types of walls, metal screens, mirrors, etc.
- Do not place the antenna near columns, which may throw shadows and reduce the coverage area.
- Keep the antenna away from metal ducts (such as canalization, air-conditioning etc.).
- Please bear in mind that other wireless devices such as telephones, microwaves, etc., can temporarily interfere with the quality of the radio signal.
- We do not recommend installing antennas near, or between, racks containing communication devices, computers, etc. Use an extension cable and place the device outside.

The following recommendations are applicable to all wireless devices:

- Do not touch or move the antenna while the device is transmitting or receiving.
- Do not touch any equipment containing devices that radiate, where the antenna is very close to (or touching) any exposed part of the body while transmitting (particularly the face and eyes).
- Do not install the device in areas where the atmosphere is potentially explosive.
- Wireless devices can cause interferences in other devices. Do not use the device in areas where medical equipment is installed.
- To ensure the R&TTE 1999/5/EC directive is complied with, the device must be at least 15 cm away from a person's body when operating.

3.6.5 Wireless LAN Antenna Connection (Wi-Fi connectors)

The **bintec RSC** router has two RF antenna connectors for an external antenna to improve the quality of the signal received and transmitted by the Wireless LAN module.

This module is internal and can be activated by purchasing the corresponding software license. To assemble and disassemble the antennas provided with the device, just screw them into the connectors, labeled *Wi-Fi*, which are located on both lateral panels of the router.



Fig. 16: **Wi-Fi Antenna 1** and Fig. 18: **Wi-Fi Antenna 2**

3.6.6 Connecting a 3G USB device (USB connector)

The **bintec RSC** has a USB HOST 2.0 Type A connector interface that allows 3G USB modems to be connected. The interface can be activated by purchasing the corresponding software license.

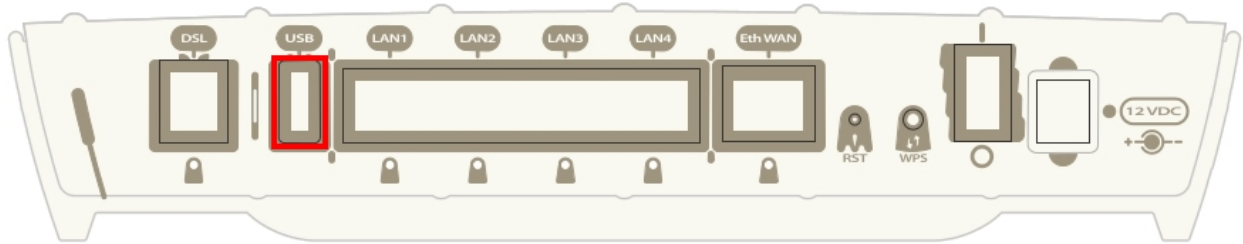

Fig. 17: USB 3G Connector

3.7 Installing the SIM card

The **bintec RSC** has a Wireless WAN interface that, in order to operate, requires one SIM card to be inserted into the device. Certain services (CDMA) provided by several carriers in some countries do not require SIM cards.

To access the 3G module SIM tray, go to the underside of the router and open the flap (as shown in the figure below).

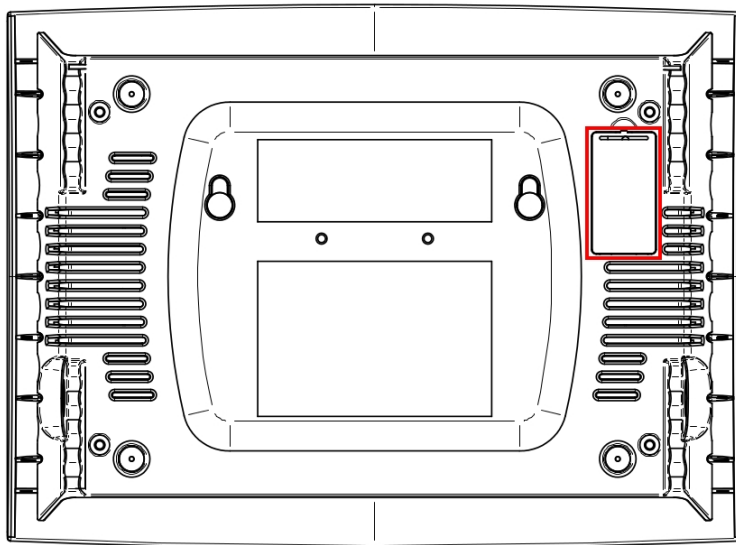

Fig. 18: 3G module SIM tray

To insert the SIM, first locate the slot and remove the flap until the SIM tray is visible. Then follow these steps:

- (1) Push the fastening in the direction indicated by the *OPEN* label.
- (2) Open the upper part of the tray.
- (3) Fully insert the SIM card using the slot guides.
- (4) Return the tray to its original position.
- (5) While pressing on the tray, push the fastening towards the inside of the tray until it is firmly in place.

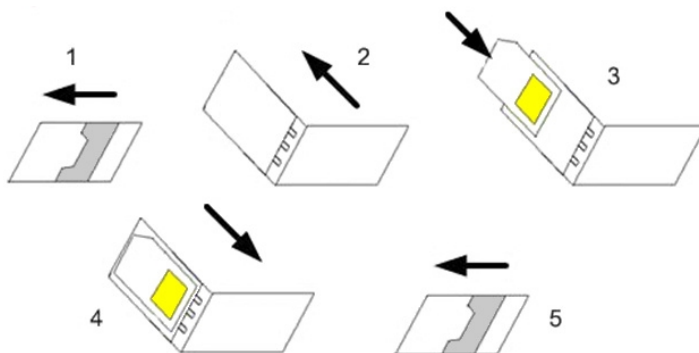

Fig. 19: Inserting the SIM in the 3G module

Chapter 4 Compliance



4.1 Manufacturer Information



<i>Brand</i>	bintec
<i>Manufacturer</i>	bintec elmeg
<i>Country</i>	Germany
<i>Postal Address</i>	Suedwestpark 94 90449 Nuremberg Germany
<i>International Phone</i>	+49 - 911 - 9673 0

4.2 Safety Warnings

	<p>The electric current in power cables, telephone lines and communication cables is dangerous. To prevent electric shocks, before installing, handling or opening the equipment covers, connect and disconnect the cables following the steps set forth in Connecting on page 11 and Disconnect on page 11.</p>
	<p>Электрический ток в кабелях и проводах может быть опасен для жизни и здоровья. Чтобы предотвратить поражение током, перед установкой оборудования, его обслуживанием и снятием панелей необходимо отсоединять кабели в соответствии с правилами, изложенными в соответствующем разделе.</p>
	<p>Le courant électrique qui circule dans les câbles d'alimentation, les lignes téléphoniques et les câbles de communication est dangereux. Afin d'éviter tout choc électrique, brancher, puis débrancher les câbles en suivant les consignes préconisées dans chaque section avant d'installer, de manipuler ou d'ouvrir les caches de l'équipement.</p>
	<p>Der elektrische Strom in Strom-, Telefon- und Datenkabeln ist gefährlich. Um Elektroschocks zu vermeiden, trennen Sie vor der Installation, der Bedienung oder dem Öffnen des Geräts die Kabel wie in den Abschnitten Verbinden und Trennen beschrieben.</p>
	<p>La tensión eléctrica de los cables de alimentación, de los cables de la línea telefónica y de los cables de comunicación es peligrosa. Para evitar descargas, antes de instalar, mover o abrir las cubiertas de este equipo, conecte y desconecte los cables siguiendo el orden que se detalla en los apartados "Conectar" y "Desconectar".</p>
	<p>All interconnected communication devices should be plugged to THE SAME GROUNDED POWER OUTLET, which should at the same time be of good quality (lower than 10 ohms).</p> <p>Whether the workplace is provided with an uninterrupted power supply system (UPS), regulated supply or it is independent from the rest (such as lighting, etc.); it is highly recommended that all data devices should be connected to the same power source. This will avoid operating and premature aging problems of drivers and other components.</p>

	<p>Убедитесь в том, что все связанные устройства связи подключены к ОДНОЙ И ТУ ЖЕ ЗАЗЕМЛЕННОЙ ШТЕПСЕЛЬНОЙ РОЗЕТКЕ высокого качества (сопротивление не превышает 10 Ом).</p> <p>Проверьте, оборудовано ли рабочее место источником бесперебойного питания (ИБП), источником регулируемого питания, или оно является независимым от других систем (таким как освещение и т.п.); строго рекомендуется подключать все информационные устройства к одному источнику питания. Это поможет предотвратить эксплуатационные проблемы и преждевременное старение приводов и других деталей.</p>
	<p>Tous les dispositifs de communications interconnectés doivent être branchés sur la même prise correctement mise à la terre, qui doit être de bonne qualité (moins de 10 ohms).</p> <p>Soit le lieu de travail équipé d'un système d'alimentation sans interruption (ASI), alimentation régulée ou indépendante du reste (comme l'éclairage, etc), il est fortement recommandé que tous les dispositifs de données soient reliés à la même source d'alimentation. Cela permettra d'éviter des problèmes de fonctionnement et de vieillissement prématuré de drivers et d'autres composants.</p>
	<p>Alle miteinander verbundenen Kommunikationsgeräte sollten mit der gleichen geerdeten Stromversorgung verbunden werden. Diese sollte von hoher Qualität sein (niedriger als 10 Ohm).</p> <p>Unabhängig davon, ob der Arbeitsplatz über eine unterbrechungsfreie Stromversorgung (UPS) oder eine geregelte Versorgung verfügt oder unabhängig von der weitere Installation (z. B. Licht) ist – es wird dringend empfohlen, alle Geräte an die gleiche Spannungsversorgung anzuschließen. Dies beugt Problemen im Betrieb sowie Problemen der vorzeitigen Alterung von Komponenten vor.</p>
	<p>Todos los equipos de comunicaciones interconectados deberán estar unidos a UNA MISMA TOMA DE TIERRA, a ser posible de buena calidad (inferior a 10 ohmios).</p> <p>Si la instalación está dotada de un Sistema de Alimentación Ininterrumpida (SAI), alimentación estabilizada, o bien es independiente del resto (alumbrado, etc.), conecte todos los equipos de comunicaciones a la misma fuente de alimentación. Así, se ahorrará problemas de funcionamiento y envejecimiento prematuro de drivers y demás componentes.</p>
	<p>Never install the SIM cards when the device is switched on.</p> <p>Always disconnect the device from the main power supply before installing the SIM cards.</p> <p>Always disconnect the device before removing the casing to access the trays.</p> <p>When inserting the SIM cards, please protect yourself against electrostatic discharges (ESD).</p> <p>Do not touch the SIM card connectors.</p>
	<p>Никогда не устанавливайте SIM-карты, когда устройство включено.</p> <p>Перед установкой SIM-карт отключите устройство от источника питания.</p> <p>Всегда отключайте устройство перед тем, как снять корпус и извлечь лотки.</p> <p>При установке SIM-карты, пожалуйста, защитите себя от электростатических разрядов (ESD).</p> <p>Не прикасайтесь к контактам SIM-карты.</p>
	<p>N'installez jamais la carte SIM lorsque l'appareil est allumé.</p>

	<p>Débranchez toujours l'appareil de l'alimentation électrique principale avant d'insérer les cartes SIM.</p> <p>Débranchez toujours l'appareil avant de retirer le boîtier pour accéder aux baies.</p> <p>Lors de l'insertion de la carte SIM, protégez-vous contre les décharges électrostatiques (ESD).</p> <p>Ne touchez pas les connecteurs des cartes SIM.</p>
	<p>Installieren Sie keine SIM-Karten, solange das Gerät eingeschaltet ist.</p> <p>Trennen Sie das Gerät immer von der Stromversorgung, bevor Sie eine SIM-Karte installieren.</p> <p>Trennen Sie das Gerät immer von der Stromversorgung, bevor Sie das Gehäuse für einen Zugang zu den SIM-Halterungen öffnen.</p> <p>Schützen Sie sich gegen elektrostatische Entladung (ESD), wenn Sie eine SIM-Karte installieren.</p> <p>Berühren Sie die SIM-Karten-Kontakte nicht.</p>
	<p>No instale nunca las tarjetas SIM con el equipo encendido.</p> <p>Desconecte siempre el equipo de la red antes de instalar las tarjetas SIM.</p> <p>Desconecte siempre el equipo antes de desmontar la carcasa para acceder a las bandejas.</p> <p>Al insertar las tarjetas SIM, protéjase contra descargas electroestáticas (ESD).</p> <p>No toque los conectores de las tarjetas SIM.</p>
	<p>The equipment is intended to be installed by Service Personnel and only handled by qualified personnel. If not, the device may be damaged and malfunction.</p>
	<p>Оборудование должно эксплуатироваться квалифицированным персоналом; в противном случае устройство может быть повреждено и впоследствии работать неисправно.</p>
	<p>L'équipement est destiné à être installé par le Personnel de Service et seulement manipulé par du personnel qualifié. Sinon, l'appareil risque d'être endommagé et dysfonctionner.</p>
	<p>Das Gerät ist für eine Montage durch Servicepersonal ausgelegt und darf nur von qualifiziertem Personal gehandhabt werden. Andernfalls kann es zur Beschädigung des Geräts und zu Fehlfunktionen kommen.</p>
	<p>El equipo está diseñado para ser instalado por personal del servicio técnico y su manejo debe realizarlo personal cualificado. De lo contrario, el equipo puede resultar dañado y quedar inservible.</p>
	<p>The equipment must be used with the power supply provided by the manufacturer.</p>
	<p>Оборудование должно использоваться с источником питания поставляемым</p>

	производителем.
	L'équipement doit être utilisé avec la source d'alimentation fournie par le fabricant.
	Das Gerät muss mit dem vom Hersteller gelieferten Netzteil betrieben werden.
	El equipo debe ser usado con la fuente de alimentación proporcionada por el fabricante.
	The screws must go into a wall stud (wood) or a wall anchor of the appropriate type for the wall. Screws into drywall are not strong enough to mount the router.
	Болты должны входить в стойки каркаса в стенах (деревянные) или стеновые анкеры соответствующего типа. Завинчивание болтов в гипсокартон не является достаточно надежным для монтажа маршрутизатора.
	Les vis doivent aller dans un poteau mural (bois) ou un ancrage murau du type approprié. Vis en plaques de plâtre ne sont pas assez forts pour monter le routeur.
	Die Schrauben müssen in einen Dübel oder Wandanker geschraubt werden, der für die jeweilige Art der Wand geeignet ist. Schrauben in einer Trockenbauwand sind nicht stabil genug, um den Router zu halten.
	Los tornillos deben ir atornillados en un taco de pared (de madera) o del tipo adecuado según la clase de pared. Los tornillos que se montan directamente en los paneles de yeso no son lo bastante resistentes para soportar el router.
	If you install the screws in drywall, use hollow-wall anchors (8 mm – 5/16 inch) to secure the screws. If the screws are not properly anchored, the strain of the cables connected to the router back panel could pull the router from the wall.
	Если вы установите винты в гипсокартона , используйте полым дюбели (8мм - 5/16 дюйма) , чтобы обеспечить винты. Если винты крепления закручены недостаточно плотно, маршрутизатор может упасть со стены из-за натяжения подключенных к нему кабелей.
	Si vous installez les vis dans des cloisons sèches, utilisez des ancres creuses-murales (8 mm - 5/16 po) pour fixer les vis. Si les vis ne sont pas fixées correctement, la tension des câbles raccordés au panneau arrière du routeur pourrait tirer le routeur de la paroi.
	Wenn Sie die Schrauben in eine Trockenbauwand schrauben wollen, verwenden Sie Hohlraumdübel (8 mm – 5/16 Zoll), um die Schrauben zu sichern. Wenn die Schrauben nicht angemessen verankert sind, kann Zug auf die Verkabelung an der Rückseite des Routers diesen aus der Wand reißen.
	Si instala los tornillos en paneles de yeso, utilice tacos de pared hueca (8 mm - 5/16 pulgadas) para fijar los tornillos. Si los tornillos no están bien anclados, la tensión de los cables

	conectados al panel posterior del router podría hacer que el router se cayera de la pared.
--	--

4.3 WEEE Information



The waste container symbol with the >X< indicates that the device must be disposed of separately from normal domestic waste at an appropriate waste disposal facility at the end of its useful service life.

Das auf dem Gerät befindliche Symbol mit dem durchgekreuzten Müllcontainer bedeutet, dass das Gerät am Ende der Nutzungsdauer bei den hierfür vorgesehenen Entsorgungsstellen getrennt vom normalen Hausmüll zu entsorgen ist.

El símbolo del contenedor con la cruz, que se encuentra en el aparato, significa que cuando el equipo haya llegado al final de su vida útil, deberá ser llevado a los centros de recogida previstos, y que su tratamiento debe estar separado del de los residuos urbanos.

4.4 REACH

In compliance with the REACH Candidate List, the delivered product and product packaging do not contain chemical substances above a concentration limit of 0.1% weight by weight (w/w). This declaration will be updated whenever any changes occur or other chemical substances are added to the REACH Candidate List. Information is currently provided to consumers upon request.

4.5 China RoHS



Teldat products also comply with the requirements set forth in China's Environmental Declaration and carry the "EFUP 10" label shown on the left.

Declaration of Product Toxic or Hazardous Substances 产品有毒有害物质宣告書

部件名称	有害物质					
	铅(Pb)	汞(Hg)	镉(Cd)	六价铬(Cr(VI))	多溴联苯(PBB)	多溴二苯醚(PBDE)
外壳	○	○	○	○	○	○
印刷电路板组件	✕	○	○	○	○	○
电线 & 电缆 & 接头	✕	○	○	○	○	○
天线	○	○	○	○	○	○
电源适配器	✕	○	○	○	○	○
其它配件	○	○	○	○	○	○

本表格依据 SJ/T 11364 的规定编制。

○：表示该有害物质在该部件所有均质材料中的含量均在 GB/T 26572 规定的限量要求以下。

✕：表示该有害物质至少在该部件的某一均质材料中的含量超出 GB/T 26572 规定的限量要求。

部件仍符合欧盟指令 2011/65/EU 及排外条款的规范。

此产品所标示之环保使用期限，系指在一般正常使用状况下。

(企业可在此处，根据实际情况对上表中打“✕”的技术原因进行进一步说明。)

4.6 PSU Energy Efficiency

According to Commission Regulation (EU) 2019/1782 laying down ecodesign requirements for external power supplies pursuant to Directive 2009/125/EC of the European Parliament and of the Council and repealing Commission Regulation (EC) No 278/2009, the instruction manuals for end-users shall include the following information:

<i>Model</i>	DA-60N12
<i>Manufacturer Name</i>	ASIAN POWER DEVICES INC. (APD)
<i>Manufacturer Address</i>	NO.5 LANE 83. LUNG-SOU ST, TAO-YUAN CITY, TAIWAN R.O.C.
<i>Input Voltage</i>	100-240 V AC
<i>Input AC frequency</i>	50-60 Hz
<i>Output voltage</i>	12.0 V
<i>Output current</i>	5.0 A
<i>Output power</i>	60,0 W
<i>Average active efficiency</i>	88.3%
<i>Efficiency at low load (10%)</i>	87.2%
<i>No-load power consumption</i>	0.12 W

4.7 EC Declaration of Conformity

English (EN)	<p>This equipment is in compliance with the essential requirements and other relevant provisions of:</p> <p>Directive 2014/53/EU (RED) or</p> <p>Directive 2014/30/EU (EMC)</p> <p>Directive 2014/35/EU (LVD)</p> <p>Directive 2009/125/EC (ErP)</p> <p>Directive 2011/65/EU (RoHS)</p> <p>of the European Parliament</p>
German (DE) Deutsch	<p>Dieses Gerät entspricht den grundlegenden Anforderungen und den weiteren entsprechenden Vorgaben der Richtlinie</p> <p>Richtlinie 2014/53/EU (RED) oder</p> <p>Richtlinie 2014/30/EU (EMC)</p> <p>Richtlinie 2014/35/EU (LVD)</p> <p>Richtlinie 2009/125/EG (ErP)</p> <p>Richtlinie 2011/65/EU (RoHS)</p> <p>des Europäischen Parlaments.</p>
Spanish (ES) Español	<p>Este dispositivo cumple con los requisitos esenciales y con las normas correspondientes de las siguientes directivas:</p> <p>Directiva 2014/53/UE (RED) o</p> <p>Directiva 2014/30/UE (EMC)</p> <p>Directiva 2014/35/UE (LVD)</p> <p>Directiva 2009/125/CE (ErP)</p> <p>Directiva 2011/65/UE (RoHS)</p> <p>del Parlamento Europeo</p>



Note

—Directive 2014/53/EU (RED) replaces Directive 1999/5/EC (R&TTE) on 13th June 2016

The EC declaration of conformity and additional product documentation can be accessed here:

<http://www.bintec-elmeg.com>

4.8 CE Marking

This equipment is in conformity with the CE procedures and marking.



4.9 National Restrictions

In accordance with Article 10 of 2014/53/EU, we inform you that, for authorization purposes, national restrictions and requirements may apply. These can evolve over time. bintec elmeg recommends that you check with local authorities what the latest status of national regulations is.

This product is supplied without any antennas. Choosing antennas is at the discretion of the operator, but said party is responsible for complying with local regulations.

Make sure that the characteristics of the antennas used match the regulations applicable to the installation's location.

4.10 Operating Frequency

To check the operating frequencies working in the device, see Appendix [RF LTE Specifications](#) on page 34 ,[RF GSM/WCDMA Specifications](#) on page 34 and [WI-FI Specifications](#) on page 35

4.11 FCC Statement

4.11.1 Federal Communications Commission Interference

This equipment has been tested and found to comply with the limits for a Class B digital device, pursuant to Part 15 of the FCC Rules. These limits are designed to provide reasonable protection against harmful interference in a residential installation.

This equipment generates, uses and can radiate radio frequency energy and, if not installed and used in accordance with the instructions, may cause harmful interference to radio communications. However, there is no guarantee that interference will not occur in a particular installation. If this equipment does cause harmful interference to radio or television reception, which can be determined by turning the equipment off and on, the user is encouraged to try to correct the interference through one of the following means:

- Reorient or relocate the receiving antenna.
- Increase the separation between the equipment and receiver.
- Connect the equipment into an outlet on a circuit different from that to which the receiver is connected.
- Contact the dealer or an experienced radio/TV technician for help.

FCC Caution: Any changes or modifications not expressly approved by the party responsible for compliance could void the user's Authority to operate this equipment.

This device complies with Part 15 of the FCC Rules. Operation is subject to the following two conditions: (1) This device may not cause harmful interference, and (2) this device must accept any interference received, including interference that may cause undesired operation.

For product available in the USA/Canada market, only channel 1~11 can be operated. Selection of other channels is not possible.

This device and it's antennas(s) must not be co-located or operating in conjunction with any other antenna or transmitter except in accordance with FCC multi-transmitter product procedures.

This device is going to be operated in 5.15~5.25 GHz frequency range, it is restricted in indoor environment only.

4.11.2 FCC Radiation Exposure Statement

This equipment complies with FCC radiation exposure limits for an uncontrolled environment. Keep a minimum distance of 20 cm between the radiator and your body when installing and operating the equipment.

4.11.3 FCC Part 68 Notice

This equipment complies with Part 68 of the FCC rules and the requirements adopted by the ACTA. *At the bottom* of this equipment, there is a label that contains, among other information, a product identifier [US: TLDDL01BTLDPV00A1]. If requested, this number must be provided to the telephone company.

If this equipment [Enterprise Router] causes harm to the telephone network, the telephone company will notify you in advance that temporary discontinuance of service may be required. But if advance notice isn't practical, the telephone company will notify the customer as soon as possible. Also, you will be advised of your right to file a complaint with the FCC if you believe it is necessary.

The telephone company may make changes in its facilities, equipment, operations or procedures that could affect the operation of the equipment. If this happens, the telephone company will provide advance notice in order for you to make necessary modifications to maintain uninterrupted service.

If you experience trouble with this equipment, disconnect it from the network until the problem has been corrected or until you are sure that the equipment is not malfunctioning.

Please follow any instructions for repairing that were provided (e.g. battery replacement section). Otherwise, do not alternate or repair any parts of the device that were not specified.

If the telephone company requests information on what equipment is connected to their lines, inform them of:

- (a) The telephone number that this unit is connected to,
- (b) The ringer equivalence number [01B]
- (c) The USOC jack required [RJ11C], and
- (d) The FCC Registration Number [TLD]

Items (b) and (d) are indicated on the label. The ringer equivalence number (REN) is used to determine how many devices can be connected to your telephone line. In most areas, the sum of the RENs of all devices on any one line should not exceed five (5.0). If too many devices are attached, they may not ring properly.

4.11.3.1 Service Requirements

In the event of equipment malfunction, all repairs should be performed by our Company or an authorized agent. It is the responsibility of users requiring service to report the need for service to our Company or to one of our authorized agents. The contact information can be found at:

<http://www.part68.org/tteDetails.aspx?id=95190>

4.12 IC Statement

4.12.1 CAN ICES-3 (B)/NMB-3(B)

This device complies with Industry Canada license-exempt RSS standard(s). Operation is subject to the following two conditions: (1) this device may not cause interference, and (2) this device must accept any interference, including interference that may cause undesired operation of the device.

Le présent appareil est conforme aux CNR d'Industrie Canada applicables aux appareils radio exempts de licence. L'exploitation est autorisée aux deux conditions suivantes: (1) l'appareil ne doit pas produire de brouillage, et (2) l'utilisateur de l'appareil doit accepter tout brouillage radioélectrique subi, même si le brouillage est susceptible d'en compromettre le fonctionnement.

For product available in the USA/Canada market, only channel 1~11 can be operated. Selection of other channels is not possible.

Pour les produits disponibles aux États-Unis / Canada du marché, seul le canal 1 à 11 peuvent être exploités. Sélection d'autres canaux n'est pas possible.

This device and its antennas(s) must not be co-located or operating in conjunction with any other antenna or transmitter except in accordance with IC multi-transmitter product procedures.

Cet appareil et son antenne (s) ne doit pas être co-localisés ou fonctionner en association avec une autre antenne ou transmetteur.

The device could automatically discontinue transmission in case of absence of information to transmit, or operational failure. Note that this is not intended to prohibit transmission of control or signaling information or the use of repetitive codes where required by the technology.

Le dispositif pourrait automatiquement cesser d'émettre en cas d'absence d'informations à transmettre, ou une défaillance opérationnelle. Notez que ce n'est pas l'intention d'interdire la transmission des informations de contrôle ou de signalisation ou l'utilisation de codes répétitifs lorsque requis par la technologie.

The device for the band 5150-5250 MHz is only for indoor usage to reduce potential for harmful interference to co-channel mobile satellite systems.

Les dispositifs fonctionnant dans la bande 5150-5250 MHz sont réservés uniquement pour une utilisation à l'intérieur afin de réduire les risques de brouillage préjudiciable aux systèmes de satellites mobiles utilisant les mêmes canaux.

4.12.2 IC Radiation Exposure Statement

This equipment complies with IC RSS-102 radiation exposure limits for an uncontrolled environment. Keep a minimum distance of 20 cm between the radiator and your body when installing and operating the equipment.

Déclaration d'exposition aux radiations au Canada:

Cet équipement est conforme aux limites d'exposition aux rayonnements IC établies pour un environnement non contrôlé.

Cet équipement doit être installé et utilisé avec un minimum de 20 cm de distance entre la source de rayonnement et votre corps.

4.12.3 For Industry Canada only

Under Industry Canada regulations, this radio transmitter may only operate using an antenna of a type and maximum (or lesser) gain approved for the transmitter by Industry Canada.

To reduce potential radio interference to other users, the antenna type and its gain should be so chosen that the equivalent isotropically radiated power (e.i.r.p.) is not more than that necessary for successful communication.

This radio transmitter (IC: 11046A-TLDPV00A1) has been approved by Industry Canada to operate with the antenna types listed below with the maximum permissible gain and required antenna impedance for each antenna type indicated.

Antenna types not included in this list, having a gain greater than the maximum gain indicated for that type, are strictly prohibited for use with this device:

Model	Impedance	Gain	Power
EDA-8709-25GR2-A9	50 Ohm Nominal	2dBi (Typ.)	1W

4.12.4 IC Notice

This product meets the applicable Industry Canada technical specifications.

Le présent matériel est conforme aux spécifications techniques applicables d'Industrie Canada.

The Ringer Equivalence Number (REN) is an indication of the maximum number of devices allowed to be connected to a telephone interface. The termination of an interface may consist of any combination of devices subject only to the requirement that the sum of the RENs of all the devices not exceed five.

L'indice d'équivalence de la sonnerie (IES) sert à indiquer le nombre maximal de terminaux qui peuvent être raccordés à une interface téléphonique. La terminaison d'une interface peut consister en une combinaison quelconque de dispositifs, à la seule condition que la somme d'indices d'équivalence de la sonnerie de tous les dispositifs n'excède pas cinq.

Appendix A Technical Information

A.1 Troubleshooting

The following table can help you solve problems when installing the device. If you cannot solve the problem, contact your dealer for more information.

Symptom	Solution
No LED lights up on the router.	Check the power supply to the router (power source, ON/OFF switch, main power outlet).
You have forgotten the access password for the router.	Ignore the configuration through the RST button (as explained in the relevant section).
The <i>DSL</i> LED never lights up in green.	If the device has an xDSL interface available, check the connection to the network or to the splitter and make sure that the telephone line you have connected supports xDSL service.
The <i>Eth WAN</i> LED never lights up in green.	Check the Ethernet cable and the connection to the network.
The <i>Wi-Fi</i> LED never lights up in green.	Check the router's configuration and that of the remote station(s). Check the appropriate license is available for use.
The <i>USB</i> LED never lights up in green.	Check that the device inserted in the USB connector is supported by the router. Please check the following website support@bintec-elmeg.com to obtain a list of supported 3G USB modems. Check the appropriate license is available for use.

A.2 Updating the software

The **bintec RSC** router can be updated to new releases. Please contact your distributor for further details on new releases.

There are various ways to update one of our routers. For further information, please see manual: *bintec Dm748-I Software Updating*.

The software required to update one of our routers is supplied in a format known as **distribution**. This consists of a single file, which contains all the files needed to update your device as well as in-depth information on the contents of the files.

The **bintec RSC** incorporates independent modules for the Wireless WAN interface. You can pick modules from different manufacturers or choose several modules from the same provider, depending on the technology used. Generally, the modules' firmware is independent from the device's software. There is an UPGRADE file for each Wireless WAN module. Please ask your distributor for the correct UPGRADE file (according to the module in your device). The document describing the Cellular interface (manual Dm 781-I) explains how to UPGRADE the module.

A.3 Connectors

A.3.1 LAN Connector

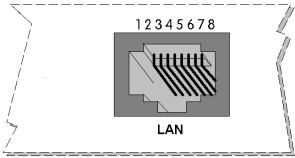
RJ45 LAN	RJ45 PIN	FE Signals	GE Signals
	1	BI-DA+	BI-DA+
	2	BI-DA-	BI-DA-
	3	BI-DB+	BI-DB+
	4	--	BI-DC+
	5	--	BI-DC-
	6	BI-DB-	BI-DB-
	7	--	BI-DD+
	8	--	BI-DD-

A.3.2 WAN Connector

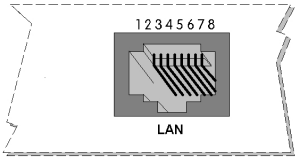
RJ45 WAN	RJ45 PIN	FE Signals	GE Signals
	1	BI-DA+	BI-DA+
	2	BI-DA-	BI-DA-
	3	BI-DB+	BI-DB+
	4	--	BI-DC+
	5	--	BI-DC-
	6	BI-DB-	BI-DB-
	7	--	BI-DD+
	8	--	BI-DD-

A.3.3 WWAN/Cell Connector (female)

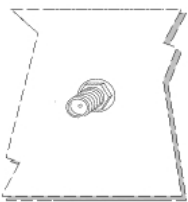
	PIN	ANT
	Internal	RF in/out
	External	GND

A.3.4 WLAN/WiFi Connector (male)

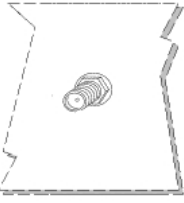
	PIN	ANT
	Internal	RF in/out
	External	GND

A.3.5 DSL Connector

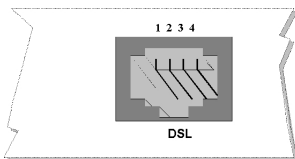
RJ11 DSL	RJ11 PIN	DSL
	1	--
	2	--
	3	Line
	4	Line
	5	--
	6	--

A.3.6 USB Connector

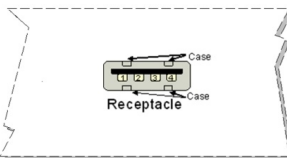
USB Type A	PIN	USB
	1	VCC
	2	DATA-
	3	DATA+
	4	GND
	Shell	Shield

A.3.7 Configuration Connector

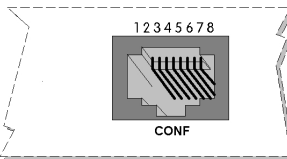
RJ45 CONFIGURATION	RJ45 PIN	CONF
	1	--
	2	RxD
	3	GND
	4	--
	5	--
	6	GND
	7	TxD
	8	--

A.3.8 Power Supply Connector

PIN	ANT
Internal	POSITIVE.
External	NEGATIVE.

A.4 Technical Specifications

A.4.1 Hardware Architecture

PROCESSORS	Broadcom BCM963168.
MEMORY	128 MBytes in SDRAM.
STORAGE UNIT	FLASH Memory (32 MBytes).

A.4.2 LAN Interface

PROTOCOLS	Ethernet (802.3).
PORTS	4 port Switch managed with MDI/MDX auto detection.
SPEED	10/100/1000 mbps (BaseT).
CONNECTOR	RJ45 female.

A.4.3 WAN Interface

STANDARDS	Ethernet (802.3).
SPEED	10/100/1000 mbps (BaseT).
CONNECTOR	RJ45 female.

A.4.4 DSL Interface

STANDARDS	Please see manual Dm741-I.
SPEED	Please see manual Dm741-I.
CONNECTOR	RJ11 female.

A.4.5 Wireless WAN Interface

STANDARDS	GPRS, UMTS, HSDPA, HSUPA, HSPA+, LTE ... (depends on the device's wireless WAN version.)
SPEED	Depends on the device's wireless WAN version. Please see the manual on the relevant module.
CONNECTOR	2 RF SMA female per module.
ANTENNA	Depends on the device's wireless WAN module. Please see the antenna catalog for Cellular interfaces.

A.4.6 Wireless LAN Interface

STANDARDS	802.11abgn.
FREQUENCY	2.4 GHz / 5 GHz.
SPEED	Supports all mandatory data rates specified in IEEE 802.11n up to 300 mbps, and the legacy rates specified in IEEE 802.11a/b/g including 1, 2, 5.5, 6, 9, 11, 12, 18, 24, 36, 48, and 54 mbps.
CONNECTOR	2 RF SMA male.

A.4.7 USB Interface

3G USB MODEMS	Please visit the following website support@bintec-elmeg.com to get a list of the supported 3G USB modems.
SPEED	The interface complies with the USB 2.0 (480 mbps) standard; the end speed depends on the 3G USB modem used.
CONNECTOR	USB Type A.

A.4.8 Configuration Interface

LOCAL TERMINAL	V.24 9.600-8-N-1-without flow control.
CONNECTOR	RJ45 female on the device front panel.

A.4.9 Power Supply

INPUT VOLTAGE	+12 V DC.
INPUT CURRENT	1200 mA.
JACK	5.5 mm.
INTERNAL PIN	2.5 mm.

A.4.10 External Power Supply

INPUT VOLTAGE	100-240 V AC.
INPUT CURRENT	1.0 A.
INPUT FREQUENCY	50-60 Hz.

A.4.11 Dimensions and weight

TYPE	Desktop.
LENGTH x WIDTH x HEIGHT	242 x 179 x 48 mm.
WEIGHT	0.8 kg.

A.4.12 Environmental Specifications

TEMPERATURE	OPERATING NORMALLY: 0 °C to 40 °C STORED: -30 °C to 85 °C
RELATIVE HUMIDITY	On: 5 % to 90 %

Appendix B Radio Information

B.1 RF LTE Specifications

The LTE equipment model with the MC7304 module provides LTE, DC-HSPA+, HSPA+, HSDPA, HSUPA, WCDMA, GSM, GPRS, EDGE network connectivity over several radio frequency bands, in accordance with 3GPP Standards.

This product is supplied with YWX-6221SAX9-508 antennas. To comply with the regulations in force, do not pick other antennas.

Technology: LTE

Bands	Frequencies	Radiated Transmit Power
Band 3	Tx: 1710–1785 MHz Rx: 1805–1880 MHz	+21 dBm ± 1 dBm
Band 7	Tx: 2500–2570 MHz Rx: 2620–2690 MHz	+20 dBm ± 1 dBm
Band 20	Tx: 832–862 MHz Rx: 791–821 MHz	+21 dBm ± 1 dBm

Technology: UMTS(WCDMA)/ HSDPA/ HSUPA/ HSPA+/ DC-HSPA+

Bands	Frequencies	Radiated Transmit Power
Band 1	Tx: 1920-1980 MHz Rx: 2110-2170 MHz	+21 dBm ± 1 dBm
Band 8	Tx: 880–915 MHz Rx: 925–960 MHz	+21 dBm ± 1 dBm

Technology: GSM / GPRS / EDGE

Bands	Frequencies	Radiated Transmit Power
EGSM 900 (900 MHz)	Tx: 880–915 MHz Rx: 925–960 MHz	+30 dBm ± 1 dBm
DCS 1800 (1800 MHz)	Tx: 1710–1785 MHz Rx: 1805–1880 MHz	+28 dBm ± 1 dBm

B.2 RF GSM/WCDMA Specifications

The GSM/WCDMA equipment model with the MC8705 module provides WCDMA, GSM, GPRS, EDGE network connectivity over several radio frequency bands, in accordance with 3GPP Standards.

This product is supplied with YWX-6221SAX9-508 antennas. To comply with the regulations in force, do not pick other antennas.

Technology: UMTS (WCDMA)

Bands	Frequencies	Radiated Transmit Power
Band 1	Tx: 1920-1980 MHz Rx: 2110-2170 MHz	+20 dBm \pm 1 dBm
Band 8	Tx: 880–915 MHz Rx: 925–960 MHz	+20 dBm \pm 1 dBm

Technology: GSM / GPRS / EDGE

Bands	Frequencies	Radiated Transmit Power
EGSM 900 (900 MHz)	Tx: 880–915 MHz Rx: 925–960 MHz	+29 dBm \pm 1 dBm
DCS 1800 (1800 MHz)	Tx: 1710–1785 MHz Rx: 1805–1880 MHz	+26 dBm \pm 1 dBm

B.3 WI-FI Specifications

Wi-fi radio communications comply with standards 802.11a/b/g/n.

This product is supplied with EDA-8709-25GR2-A9 antennas. To comply with the regulations in force, do not pick other antennas.

Frequency Range	802.11b/g/n @ 2.4 GHz 2400-2483.5 MHz 802.11a/n @ 5 GHz 5150-5250 MHz
Operating	802.11b/g/n (HT20) @ 2.4 GHz 13 Channels 802.11n (HT40) @ 2.4 GHz 9 Channels 802.11a/n (HT20) @ 5 GHz 4 Channels 802.11n (HT40) @ 5 GHz 2 Channels
EIRP - Output Power (dBm) (tolerance \pm 2 dBm)	2.4 GHz 802.11b @ 1 Mbps 2412 ~ 2472 MHz: +18 dBm 802.11g @ 6 Mbps 2412 ~ 2472 MHz: +18 dBm 802.11n (HT20) at MCS0

2412 ~ 2472 MHz: +18 dBm

802.11n (HT40) at MCS0

2422 ~ 2462 MHz: +18 dBm

5 GHz

802.11a @ 6 Mbps

5180 MHz: +21 dBm

802.11n (HT20) at MCS0

5180 MHz: +21 dBm

802.11n (HT40) at MCS0

5190 MHz: +20 dBm