

RM5000

Installation Manual

Copyright© bintec Dm649-I Version 1.6 02/2020 bintec elmeg

Legal Notice

Warranty

This publication is subject to change.

bintec elmeg offers no warranty whatsoever for information contained in this manual.

bintec elmeg is not liable for any direct, indirect, collateral, consequential or any other damage connected to the delivery, supply or use of this manual.

Table of Contents

I	Related Documents.	1
Chapter 1	About this Guide	2
1.1	Supported devices	2
1.2	Who should read this manual?	2
1.3	When should this manual be read?	2
1.4	What is in this manual?	2
1.5	What is not in this manual?	2
1.6	How is the information organized?	2
1.7	Technical support.	2
Chapter 2	RM5000	4
2.1	Characteristics	4
2.1.1	Power supply	4
2.1.2	Hardware monitoring	4
Chapter 3	Components and Power Supply	5
3.1	Components	5
3.1.1	Front panel	5
3.1.2	Rear panel.	7
3.1.3	Side panels	8
3.1.4	Underside panel	9
3.2	Expansion slot	9
3.3	Installation in a rack.	10
3.3.1	Standalone	12
3.3.2	Wall mounting	12
3.4	Plug-in modules	12
3.4.1	Installation	12
3.4.2	Uninstall	13
3.5	Power source	13
3.5.1	External power source.	13
3.5.2	PoE source	14
3.6	RST button	17
3.6.1	Rebooting the device	17
3.6.2	Default configuration	17
3.7	Connecting the data.	17

3.7.1	8-port Ethernet switch	18
3.7.2	WAN connection	18
3.7.3	WWAN antenna connection (cell connector)	18
3.7.4	Wireless LAN antenna connection (Wi-Fi connectors)	19
3.7.5	Connecting a 3G USB device (USB connector)	20
3.7.6	Connecting for configuration	20
3.8	Installing the SIM card	20
3.9	Optional storage	22
3.9.1	Procedure to install a hard disk	22
3.9.2	Procedure to install a flash memory expansion SD	24
Chapter 4	Compliance	25
4.1	Manufacturer information	25
4.2	Safety warnings	27
4.3	WEEE information	28
4.4	REACH	28
4.5	PSU energy efficiency	28
4.6	EC declaration of conformity	29
4.7	CE marking	29
4.8	Laser product	29
4.9	National restrictions	30
4.10	Operating frequency	30
Appendix A	Technical Information.	31
A.1	Troubleshooting	31
A.2	Updating the software	31
A.3	Connecting to the device	31
A.3.1	Connecting using the local console (Aux connector)	31
A.4	Connectors	32
A.4.1	LAN connector (switch)	32
A.4.2	WAN Base-T connector	33
A.4.3	WAN SFP connector	33
A.4.4	WWAN connector.	33
A.4.5	WLAN connector	33
A.4.6	USB connector	34
A.4.7	Configuration connector	34
A.4.8	Power supply connector	34
A.5	Technical specifications	34

A.5.1	Hardware architecture	34
A.5.2	LAN interface	35
A.5.3	WAN Base-T interface.	35
A.5.4	WAN SFP interface	35
A.5.5	Wireless WAN interface	36
A.5.6	Wireless LAN interface	39
A.5.7	USB interface	39
A.5.8	Configuration interface	39
A.5.9	Power supply	39
A.5.10	Dimensions and weight	39
A.5.11	Environmental specifications	39
Appendix B	Radio Information.	40
B.1	RF WAN specifications	40
B.2	WI-FI specifications	41

I Related Documents

bintec Dm748-I Software Updating

Chapter 1 About this Guide

This installation guide for the **RM5000** router contains information on how to correctly install this device in a working environment.

1.1 Supported devices

The information provided in this installation guide only applies to the **RM5000** router.

1.2 Who should read this manual?

This manual should be read by the support personnel who need to configure, maintain and monitor the device.

1.3 When should this manual be read?

Read this guide as soon as you are ready to familiarize yourself with the device and its components.

This manual will help you understand your new device in greater depth.

1.4 What is in this manual?

This installation guide contains the following information:

- A description of the features available in the **RM5000** router.
- Technical specifications.
- Power supply requirements.
- Elements that can be connected when the router is operating.
- How to install and uninstall the modules and power sources.
- A description of the device LEDs and connectors.
- Troubleshooting.

1.5 What is not in this manual?

This manual does not contain information relative to the device software or its configuration. For information on how to configure this device, please see the relevant protocol manuals found in the bintec website: <http://www.bintec-elmeg.com>

1.6 How is the information organized?

Each chapter focuses on a specific part of the hardware and its components. All descriptive and technical specifications, and information on a component, can be found in the relevant chapter.

1.7 Technical support

bintec elmeg offers a technical support service. Device software can be upgraded on a regular basis for maintenance purposes and for new features.

Contact information:

Web: <http://www.bintec-elmeg.com>

Tel. No: +49 - 911 - 9673 0

Fax: +49 - 911 - 688 0725

Email: support@bintec-elmeg.com

Chapter 2 RM5000

2.1 Characteristics

2.1.1 Power supply

For further information on the different **RM5000** power supplies, please see [Components and Power Supply](#) on page 5, [Power source](#) on page 13.

2.1.2 Hardware monitoring

The LEDs on the front panel are used to monitor the hardware in the **RM5000** router. These LEDs provide visual information on the state of the device and reference the condition of the hardware components, indicating whether there is connectivity, data flow, etc.

For further information on the LED panel, please see [Components](#) on page 5.

Chapter 3 Components and Power Supply

The following chapter provides detailed information on the chassis of the **RM5000** router and its components. This information includes:

- Components.
- Information on assembly.
- Installing and uninstalling modules.
- Power supply.
- RST button.
- Data connection.
- SIM card installation.
- Hard disk installation.

3.1 Components

3.1.1 Front panel

The following figure shows the front panel.

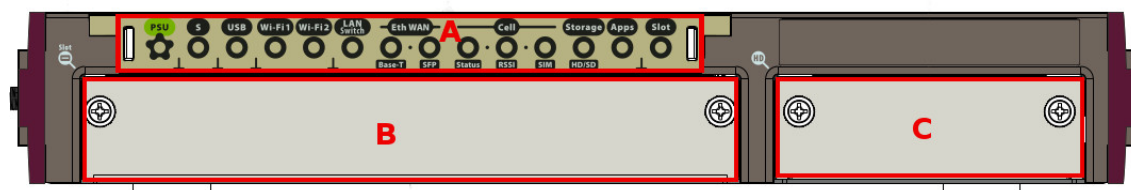

Fig. 1: Front Panel

The front panel components are as follows:

Front panel components

Item	Description
A	LED panel.
B	Slot for expansion card.
C	Slot for hard disk.

The LED panel provides information on the status of components (whether they are active or not) and on network activity.

LEDs

LED	Definition	Status Indication
PSU	Power / Switch On-Off	Off -> no power through PSU. On -> powered through PSU.
S	General Status / Default Configuration Process	Off -> system off. Red -> Error, component operating incorrectly. Green -> System initialized and operating. Amber (blink) -> Default configuration.

USB	USB Interface Status	<p>Off -> system stopped.</p> <p>Red -> interface is unavailable because it is installing, disabled (shutdown) or due to auto-test failure.</p> <p>Amber -> idle:</p> <ul style="list-style-type: none"> • Rapid blinking. It has not registered in the network or the quality is insufficient. • Slow blinking. GSM connection (GPRS). • Steady. WCDMA (UMTS / HSDPA) connection. <p>Blinking (green/red) -> activity/maintenance.</p>
Wi-Fi 1	Wifi-1 Interface Status	<p>Off -> Interface not available or not installed (not supported).</p> <p>Red -> Interface not found, no data connection.</p> <p>Amber -> Connecting.</p> <p>Green -> Communications established. Blinking: depends on the activity.</p>
Wi-Fi 2	Wifi 2 Interface Status	<p>Off -> Interface not available or not installed (not supported).</p> <p>Red -> Interface not found, no data connection.</p> <p>Amber -> Connecting.</p> <p>Green -> Communications established. Blinking: depends on the activity.</p>
LAN Switch	LAN switch interface activity	<p>Green -> connected. Blinking: connection data activity.</p> <p>Red -> disconnected.</p> <p>Off -> interface off.</p>
Eth WAN	Base-T	<p>Green -> connected. Blinking: connection data activity.</p> <p>Off -> not used.</p>
	SFP	<p>Green -> connected. Blinking: connection data activity.</p> <p>Off -> not used.</p>
Cell	Status	<p>Off -> system stopped.</p> <p>Red -> interface is unavailable because it is installing, disabled (shutdown) or due to auto-test failure.</p> <p>Amber -> idle:</p> <ul style="list-style-type: none"> • Rapid blinking. It has not registered in the network or the quality is insufficient. • Slow blinking. GSM connection (GPRS). • Steady. WCDMA (UMTS / HSDPA) connection. <p>Green -> connected. Blinking: connection data activity.</p>
	RSSI.	Green -> Good level.
	Coverage indication	<p>Amber -> Fair level.</p> <p>Red -> Critical level.</p>

	SIM	Green -> External SIM active. Amber -> Internal SIM active.
Storage (HD/SD)	HDD / SDD Status	Off -> Hard disk or SD card is not connected or is inactive. Green -> Detected hard disk or SD card. Amber -> Testing hard disk or SD card. Red -> Error.
Apps	Apps Information	Off -> no applications detected. Green -> applications detected. Amber -> testing application. Red -> application error.
Slot	Expansion Slot Information	Off -> There is no card in the expansion slot. Red -> interface down. Amber -> auto test. Green -> interface up (blinking, in some cards, when there is connection data activity).

In addition to the LEDs previously described, the front panel also has LEDs linked to the Switch Ethernet interfaces.

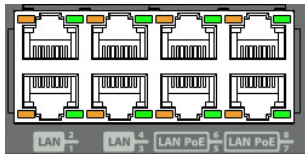

Fig. 2: Ethernet interface LEDs

The table below provides information about the LEDs associated with the Switch Ethernet interface:

Switch Ethernet interface LED indicators

LED	Description	State
Orange	PoE activity.	Please see manual <i>bintec Dm776-l Power Over Ethernet</i> .
Green	Ethernet (link) connection established.	Off -> Link has not been detected. Green -> Link detected. Blinking: connection data activity.

3.1.2 Rear panel

The following figure shows the rear panel. Here you will find the majority of the **RM5000** router connectors.

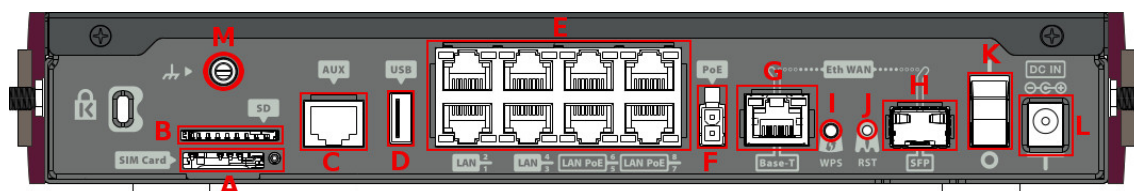

Fig. 3: Rear panel

The following table provides information on each connector, as well as a description:

Rear panel components

Item	Description
A	SIM Card. Slot where you can insert the SIM card for the external 3G module.
B	SD. Slot where you can insert a SD card.
C	Aux. Provides access to the RM5000 local console for configuring and monitoring purposes.
D	USB. Slot where you can insert a 3G USB modem.
E	8-port Gigabit Ethernet switch.
F	PoE. Connector for power supply through Ethernet (Power over Ethernet).
G	Eth WAN Base-T. WAN Gigabit Ethernet.
H	Eth WAN SFP.
I	WPS (Wireless Protected Setup). Allows for Wi-Fi network parameters to be easily and securely configured.
J	RST. Reset button. For further information on how the reset button works, please see RST button on page 17.
K	On/Off switch.
L	Power source connection (PSU).
M	Functional earthing. Usually disconnected.

3.1.3 Side panels

Four Wi-Fi and two 3G antenna connectors are located on the side panels.

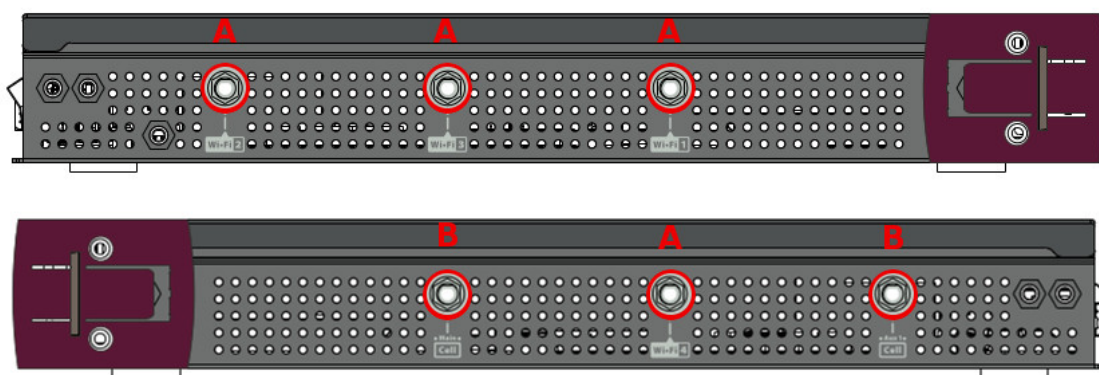

Fig. 4: Left and right side panels

The connectors are as follows:

Side panel connectors

Item	Description
A	Wi-Fi antenna connectors.
B	3G antenna connectors.

3.1.4 Underside panel

The following components are located on the underside panel:

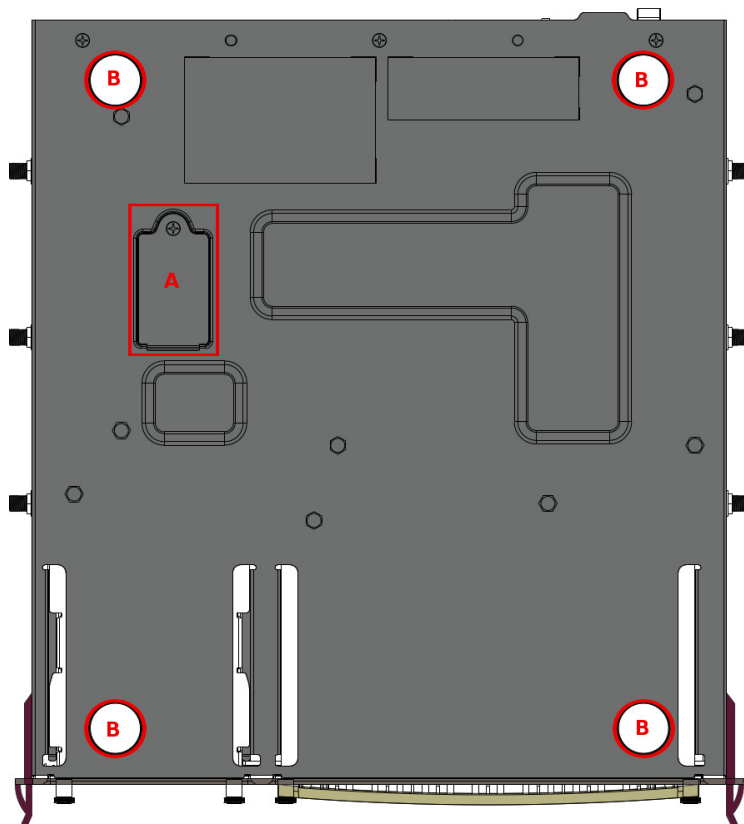

Fig. 5: Underside panel

Underside panel components

Item	Description
A	Internal 3G module SIM tray. Access from the bottom of the router.
B	Adhesive rubber feet (these are not required for rack mounting).

3.2 Expansion slot

The **RM5000** router has an expansion slot. This means you can increase its features and interfaces by inserting different cards or boards.

This slot is located on the router's front panel, as shown in the following figure:

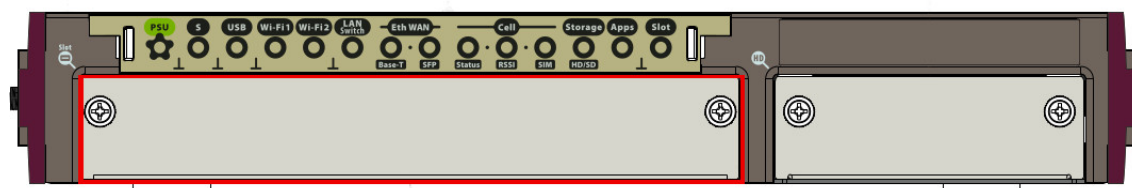

Fig. 6: Expansion slot

To correctly insert cards, please follow these steps:

- (1) Switch off the device and remove the data cables as described under [Disconnecting](#) on page 14.
- (2) Remove the device from the workplace and place it in a stable, safe location where it can be easily accessed and handled.
- (3) Unscrew the front panel screws to remove the expansion card tray.



Fig. 7: **Unscrewing the front panel screws**

- (4) Once unscrewed, pull the tray out of the front panel slot.

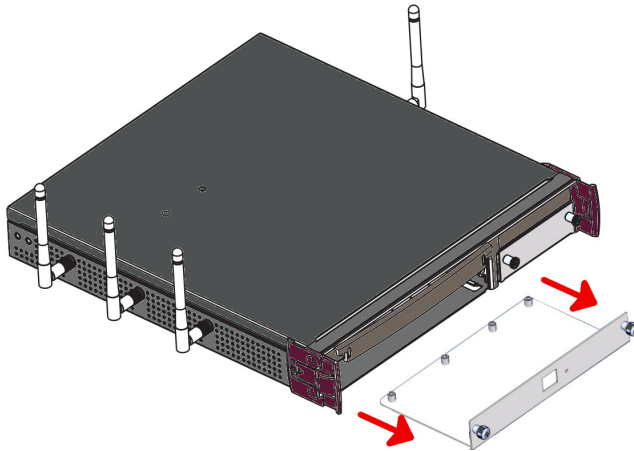

Fig. 8: **Extracting the tray from the front panel**

- (5) Finally, insert the tray (now holding the card) back into the device.

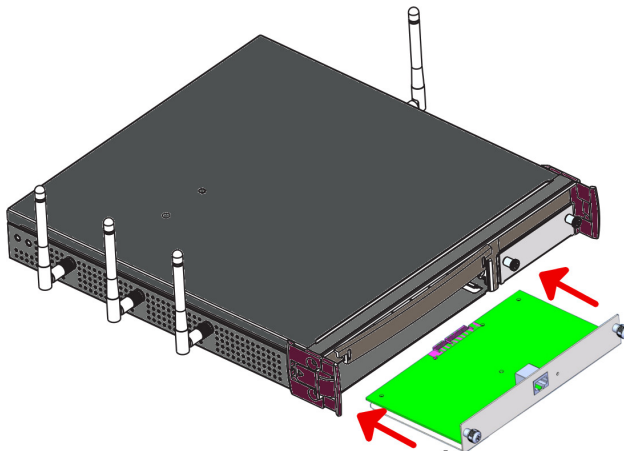

Fig. 9: **Inserting the expansion card**

- (6) Screw the tray to the device.

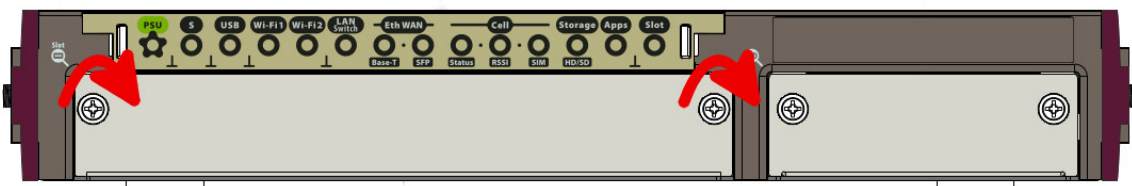

Fig. 10: **Screw the tray to the front panel**

- (7) Connect the equipment as indicated in section 3.5.1.1 "Connecting". Connect a terminal to the console and verify that the expansion card has been detected.

3.3 Installation in a rack

The **RM5000** device can be installed in a 19" rack. The necessary strips and screws are not supplied with the device and must be acquired separately.

- (1) First, remove the side tabs to free the screw holes:

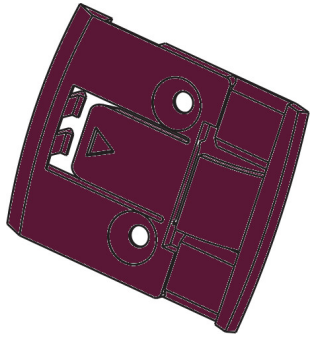

Fig. 11: The central tab that has to be removed

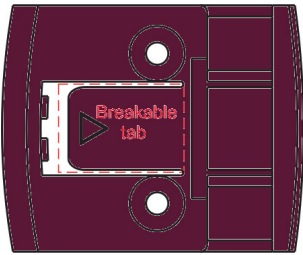

Fig. 12: Removable tab part

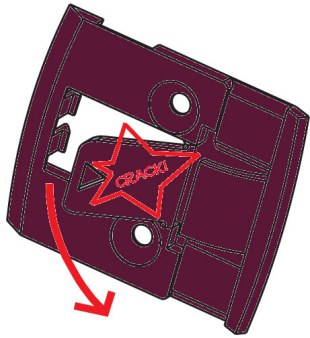

Fig. 13: Breaking off the tab

- (2) Both strips are attached to the device by means of 5 screws, as shown in the following figure:

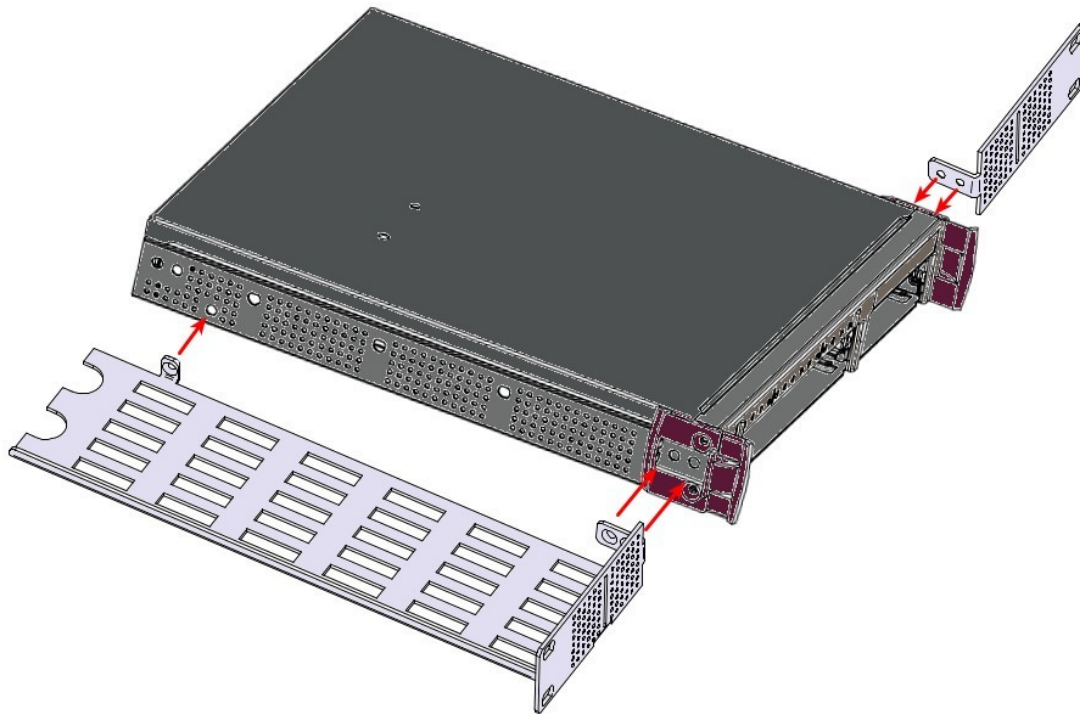

Fig. 14: Rack anchor bolts

3.3.1 Standalone

RM5000 devices can be placed as standalones on a flat, stable surface. The adhesive rubber feet must be stuck to the underside panel to prevent the router from sliding.

Make sure there is enough space around the router (for ventilation purposes) and check that the power cord and data cables can easily reach it.

3.3.2 Wall mounting

The **RM5000** cannot be mounted on a wall.

3.4 Plug-in modules

Presently, only a 3G USB modem can be inserted in the device. To view the list of supported 3G modems, please visit the following website: <http://www.bintec-elmeg.com>.

3.4.1 Installation

Simply insert the USB in the appropriate slot on the rear panel, as shown in the following figure:

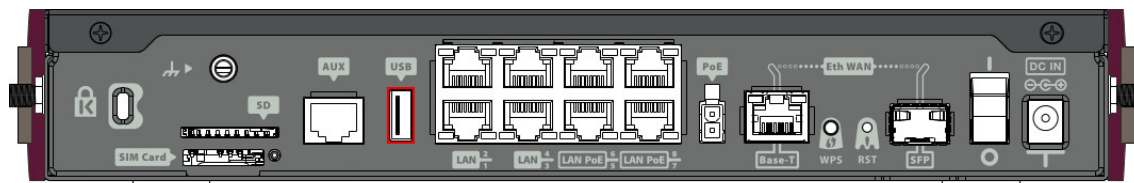

Fig. 15: USB modem insertion slot

3.4.2 Uninstall

To remove the device, simply pull it out from the slot where it was inserted. We recommend switching the equipment off before removing the USB device.

3.5 Power source

The **RM5000** router is powered through an external AC/DC power adapter.

The **RM5000** may also incorporate a card to inject PoE through the 4 ports of the 8-port switch. In this case, another external adapter is needed to provide power to the PoE module.



Note

This adapter is different from the one used to power the **RM5000** router and has a different connector.



Warning

The equipment must be used with the power supply provided by the manufacturer.

Workplace conditions. Main characteristics

- Avoid humid and/or dusty locations.
- Direct exposure to sunlight and other heat sources should be avoided. The device should not be placed amongst papers, magazines or other elements that could hinder natural air circulation.
- The device should not be placed very close to strong electromagnetic fields (such as speakers, engines, etc.).
- Knocks and/or strong vibrations should be avoided during transport, operation and storage.



Warning

Electric current in power cables, telephone lines and communication cables is dangerous. To prevent electric shocks, before installing, handling or opening the equipment covers, connect and disconnect the cables following the steps set forth in [Connecting](#) on page 14 and [Disconnecting](#) on page 14.

3.5.1 External power source

To connect the power supply to the device, please follow the steps set out in [Connecting](#) on page 14.

To avoid electric shocks, residual current circulation and other unwanted effects that affect communications, the following is recommended:



Warning

All interconnected communication devices should be plugged to THE SAME GROUNDED POWER OUTLET, which should at the same time be of good quality (lower than 10 ohms).

We recommend connecting all data devices to the same power source regardless of whether the workplace is provided with an uninterrupted power supply system (UPS), a regulated supply or is independent of other power supplies (such as lighting, etc.). This will help to prevent malfunctions and premature aging of the drivers and other components.

3.5.1.1 Connecting

- Ensure that the on/off power supply switch is in the OFF position (0).
- Make sure the power supply is NOT connected to the electricity or the device.
- Connect all data cables.
- Connect the external adapter power cable to the device.
- Connect the adapter power cable to the mains (wall socket).
- Set the device's on/off power supply switch in the ON position (1).

3.5.1.2 Disconnecting

- Set the on/off power supply switch in the OFF position (0).
- Disconnect the adapter power cable to the mains (wall socket).
- Remove the power supply cable from the device.
- Disconnect the data cables.

3.5.2 PoE source

The **RM5000** can be powered through an Ethernet cable that complies with the PoE 802.3af standard (15.4 W per port). Another external adapter and internal card are needed for this function.

The following figure shows where to connect the PoE source to the device:

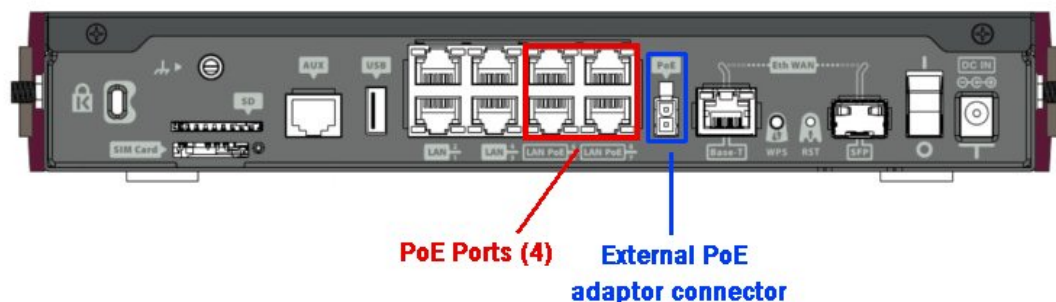

Fig. 16: PoE source connection and PoE ports



Warning

The equipment must be used with the power supply provided by the manufacturer.

3.5.2.1 Installing the MiniPoE card

To correctly insert the card, please follow these steps:

- (1) Switch off the device and remove the data cables, as described in [Disconnecting](#) on page 14.
- (2) Remove the device from the workplace and place it in a stable, safe location where it can be easily accessed and handled.
- (3) Remove the two screws from the rear panel in order to dismantle the cover that gives access to the MiniPoE card.

```

System Info:
PCB:0x14B PVR:0x80241021 SVR:0x85480010 T1024
CLKs: PLAT=400 CPU0/1/2/3=1400/1400/1400/1400 DDR(clk)=1584 LBUS=50 PCI0/1/2/3=0/0/0/0
Watchdog:Enabled
MMU Mode:Dynamic
ICache:ON DCache:ON Write-Back L2Cache:ON

Mem Info:
DRAM size: 1024 Megabytes
  BANK 0: 1024 Megabytes
FLASH: 32256 KB.
EEPROM: 16384 Bytes.

Devices:
SWITCH(8) 10/100/1000
USB 2
USB 1
NVRAM 128 KB
SECURITY ENGINE(0x0a120500)
POE CARD 0
GIGABIT ETHERNET 1
PCI device: PowerPC processor, RC
  (Bus: 0, Device: 0, Function: 0)
  (Vendor: 0x1957, Device: 0x0840)
  (Subs. Vendor: 0x0000, Subs. Device: 0x0000)
PCI device: PowerPC processor, RC
  (Bus: 10, Device: 0, Function: 0)
  (Vendor: 0x1957, Device: 0x0840)
  (Subs. Vendor: 0x0000, Subs. Device: 0x0000)
PCI device: PowerPC processor, RC
  (Bus: 20, Device: 0, Function: 0)
  (Vendor: 0x1957, Device: 0x0840)
  (Subs. Vendor: 0x0000, Subs. Device: 0x0000)
Wi-Fi1 - PCI device: network controller
  (Bus: 21, Device: 0, Function: 0)
  (Vendor: 0x168C, Device: 0x0030)
  (Subs. Vendor: 0x168C, Subs. Device: 0x3112)

Current production date: 16 12
PCIe BUS_2x to Wi-Fi1
Current PCBAREf:
S/N: 848/00110
BIOS MAC Add: 00-a0-26-b8-00-50
Num MACs: 8
>>

.....
TRYING APP DUMP
  (CONFIGURED) APPCODE1.BIN ver.: 0.11.1.2 0.0.0.0
APP CODE DUMP.....
.....
.....
.....
APP DATA DUMP.....
  Bios-stack used: 0x4000
  Bios-stack free: 0x0
  Aux-stack used: 0x11C
  Aux-stack free: 0x1EE4
Running application at: 0x00200140
License loaded successfully

Flash configuration read
Parsing text mode configuration ...

```

```
Configuration parsed
Initializing
Press any key to get started
```

Once the MiniPoE card has been installed, we can connect the PoE source to the device:

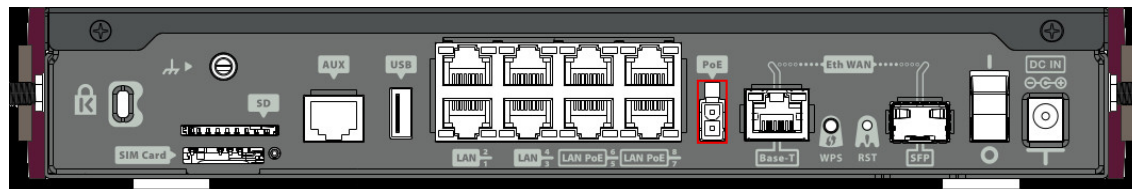

Fig. 20: Connecting the PoE source to the device through external PoE adapter connector

3.6 RST button

The different RST button features are described below.

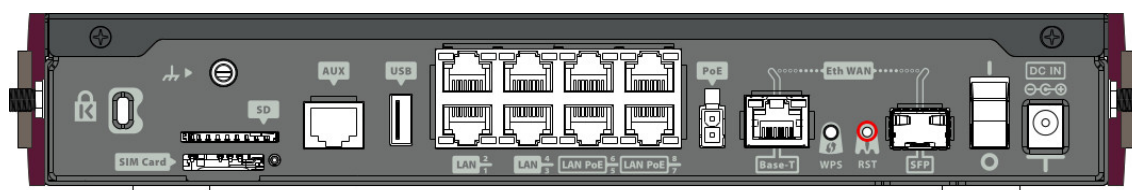

Fig. 21: RST button

3.6.1 Rebooting the device

Once the device is operating normally, pressing the RST button will force a restart.

3.6.2 Default configuration

The RST button allows you to boot the device with its default configuration through the following steps:

- With the device switched off, press and hold the RST button down while you turn on the router using the ON/OFF switch (1).
- The PSU LED (green) will light up and LED 'S' will begin to blink (amber). It will carry on blinking for 10 seconds.
- To boot the device with the default configuration, release the RST button while LED 'S' is still blinking (i.e., before the 10-second period expires).

The router's default configuration establishes a user (admin), a password (admin) and the following access IP and mask address:

- IP address: 192.168.0.254
- IP mask: 255.255.255.0



Note

Some devices leave the factory with customized settings. This personalization can mean your router's default configuration is different from the one shown above.

3.7 Connecting the data

The **RM5000** router has the following data connections.

3.7.1 8-port Ethernet switch

The **RM5000** router incorporates an 8-port 10/100/1000 Base-T switch with automatic MDI/MDIX to connect to a local area network (LAN).

Please pay careful attention to the labeling to avoid mistaking this switch for other types of ports:

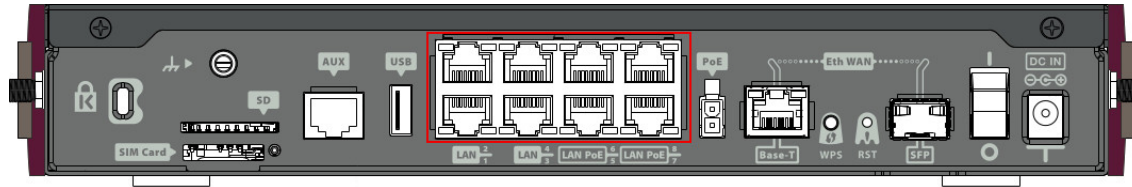

Fig. 22: LAN switch PORTS



Note

During booting and in BIOS mode, only the LAN 1 connector is available.

3.7.2 WAN connection

The **RM5000** has 1 Ethernet interface for WAN connection. This port has 2 connectors - SFP for optical link and RJ45 for 10/100/1000 Base-T link - but they cannot work simultaneously. This interface is totally independent from the switch and is handled as just one more interface.

Please pay careful attention to the labeling to avoid mistaking these ports for other types of ports:

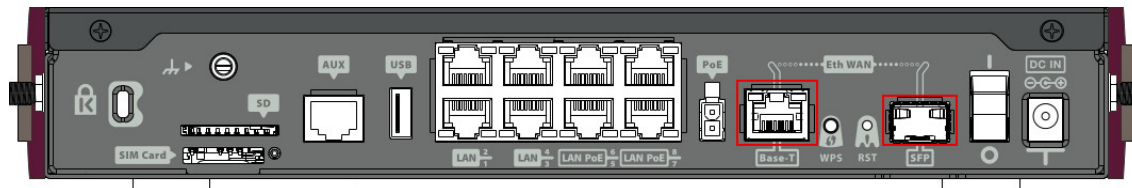

Fig. 23: WAN connectors



Note

During booting and in BIOS mode, the WAN connectors do not work.

3.7.3 WWAN antenna connection (cell connector)

The **RM5000** has two connectors for 3G antennas. To assemble or dismantle the antennas, simply screw or unscrew them into or out of the connectors labeled *Cell* (located on the right panel of the router).

Installing these antennas in the **RM5000** is essential to improve the quality of the signal received and transmitted by the cellular model.



Note

To achieve high-quality performance, the router should always have the WWAN antennas installed.

For the *cellular* interface to work, the router needs the corresponding software license.

Some cellular telephony technologies use the antenna diversity technique to improve the quality of the signal received (HSUPA, CDMA EV-DO, etc.). The **RM5000** router family incorporates several WWAN connectors for this.

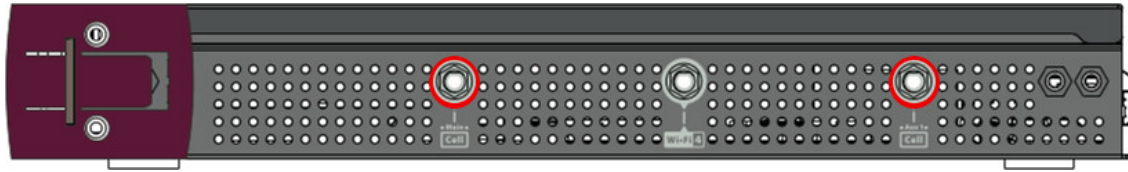

Fig. 24: WWAN Main and Aux 1 antennas

When the Main and Aux 1 antennas are not directly connected to the router but installed through extension cords, the minimum distance between the two of them must be 7 cm. The maximum recommended distance is 25 cm.

To achieve optimum performance, the radio frequency accessories installed (antennas and cables) should be those recommended by bintec.

bintec has a series of accessories (90° mount antennas, antennas for outdoor installation, antennas for ceiling installation, extension cables, etc.) for installation in different locations.

3.7.3.1 Placing the antenna

The orientation of the antenna and its location with respect to other wireless devices and radiation sources (such as communication devices, personal computers, etc.) can influence the performance of the device.

Antennas transmit and receive radio signals. This performance is also affected by environmental factors (such as the distance between the device and the base station), physical obstacles and other interferences due to radio frequencies (RF).

For optimum coverage, carry out the following instructions:

- Whenever possible, place the antenna where there are no physical obstacles. Obstacles between the antenna and the base station degrade the wireless signal. Place the antenna above ground level facing the nearest base station.
- Density of materials also affects antennas. Place them away from any type of wall, metal screens, mirrors, etc.
- Do not place the antenna near columns, which may throw shadows and reduce the coverage area.
- Keep the antenna away from metal pipes (such as those used for plumbing, air-conditioning, etc.).
- Please bear in mind that other wireless devices such as telephones, microwaves, etc., can temporarily interfere with the quality of the radio signal.
- We do not recommend installing antennas near, or between, racks containing communication devices, computers, etc. Use an extension cable and place the device outside.

The following recommendations are applicable to all wireless devices:

- Do not touch or move the antenna while the device is transmitting or receiving.
- When the antenna is transmitting, do not touch any equipment that contains devices that radiate very close to, or touching, any exposed part of the body (particularly the face and eyes).
- Do not install the device in areas where the atmosphere is potentially explosive.
- Wireless devices can cause interferences in other devices. Do not use the device in areas where medical equipment is installed.

3.7.4 Wireless LAN antenna connection (Wi-Fi connectors)

The **RM5000** has four RF antenna connectors for an external antenna to improve the quality of the signal received and transmitted by the Wireless LAN module.

These modules are internal and can be activated by purchasing the corresponding software license. To assemble or dismantle the antennas provided with the device, just screw or unscrew them into or out of the connectors labeled *Wi-Fi*. They are located on the router's rear and side panels.

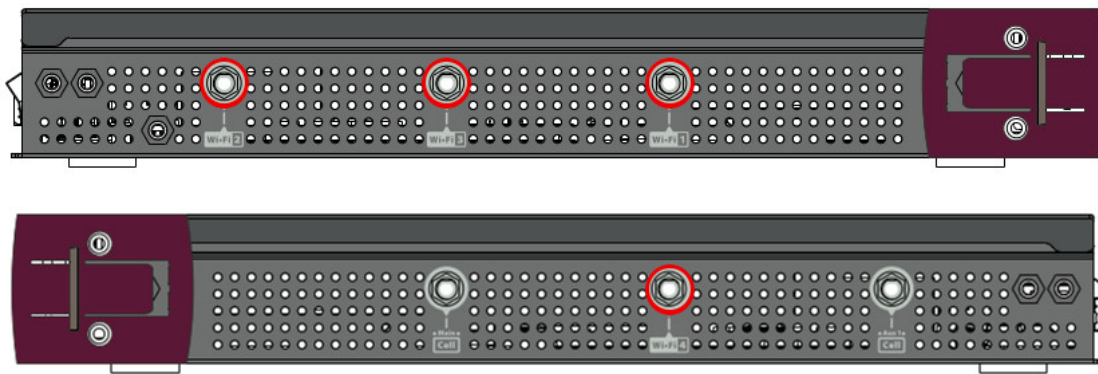

Fig. 25: Wi-Fi Antennas

3.7.5 Connecting a 3G USB device (USB connector)

The **RM5000** router has a USB HOST 2.0 Type A connector interface that allows 3G USB modems to be connected. The interface can be activated by purchasing the corresponding software license.

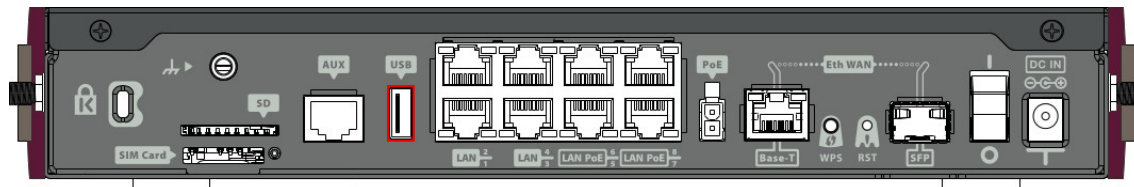

Fig. 26: 3G USB Connector

3.7.6 Connecting for configuration

The **RM5000** has a RJ45 female connector on the front panel (labeled Aux.) that provides access to the device's local console.

For further information, please see [Connecting to the device](#) on page 31.

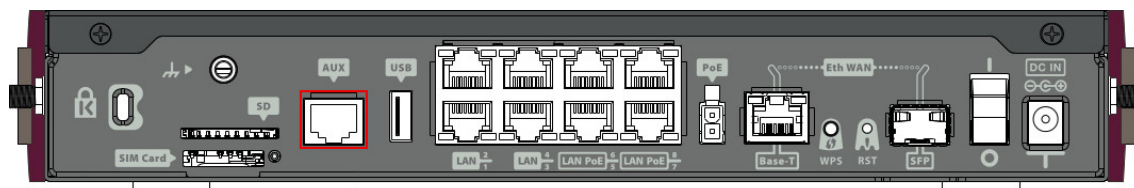

Fig. 27: Aux. Connector

3.8 Installing the SIM card

The **RM5000** is equipped with a Wireless WAN interface that may need a SIM card to operate. Some carriers in certain countries provide services (CDMA) that do not require SIM cards.

The **RM5000** is equipped with two SIM trays.

One is located on the rear panel of the router, as shown in the following figure.

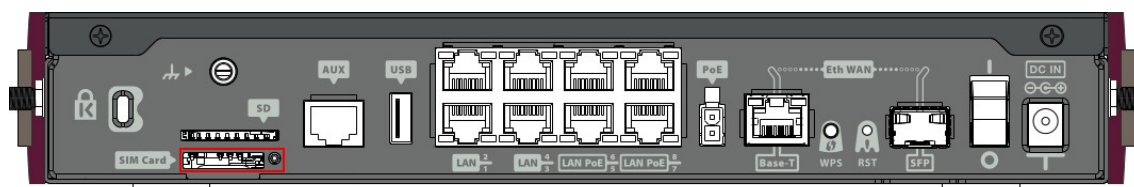

Fig. 28: External module SIM tray

To insert the SIM card in the external SIM tray, first place the device so you can see the rear panel and then carry

out the following steps:

- (1) Press the button until the SIM tray comes out.
- (2) Place the SIM on the tray.
- (3) Insert the tray in the slot and return the tray to its original position.

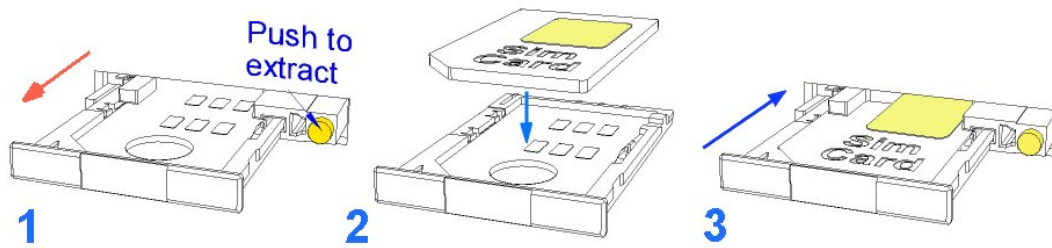

Fig. 29: Inserting the SIM in the external module

The other SIM tray is internal. To access it, you need to access the underside of the router, open the flap (as shown in the following figure) and insert the SIM card.

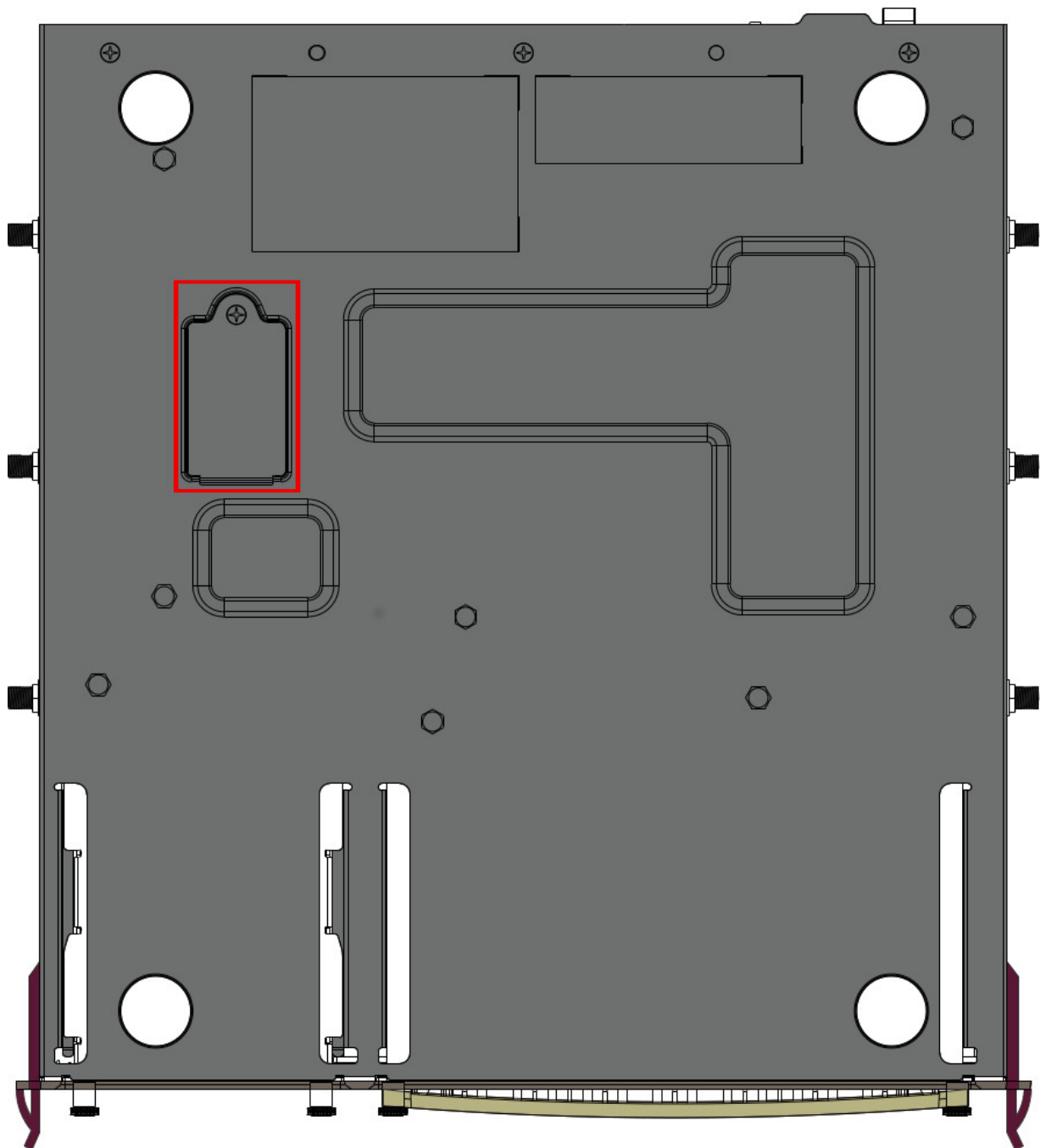

Fig. 30: Internal module SIM tray

To insert a SIM, locate the slot and remove the flap. The SIM tray is now visible. Now carry out the following steps:

- (1) Push the fastening in the direction indicated by the arrow with the word *OPEN*.
- (2) Open the upper part of the tray.
- (3) Fully insert the SIM card using the slots.
- (4) Return the tray to its original position.
- (5) While pressing the tray, push the fastening towards the word *LOCK* until it is firmly in place.

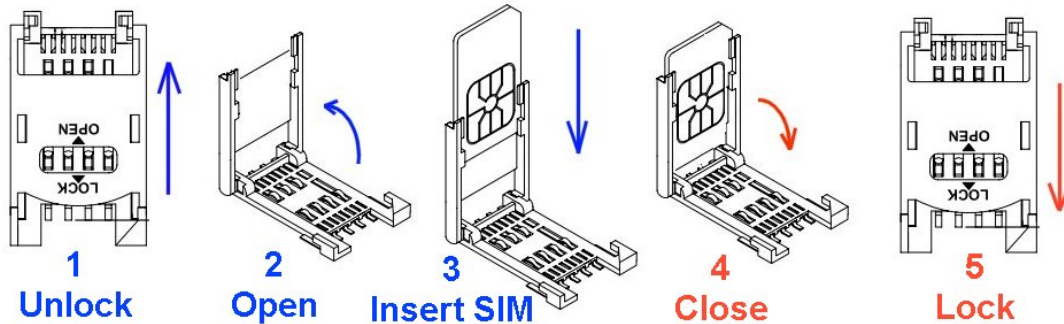

Fig. 31: Inserting the SIM in the internal tray

3.9 Optional storage

The applications running in the second core of the device processor can increase the features of the **RM5000** router.

To access said features, the device must have an internally-installed hard disk or an SD flash memory expansion.



Note

Please see the bintec website <http://www.bintec-elmeg.com> for a list of supported hard disks.

3.9.1 Procedure to install a hard disk

To correctly insert a hard disk, please carry out the following steps:

- (1) Switch off the device and remove the data cables as described under *Disconnecting* on page 14.
- (2) Remove the device from the workplace and place it on a flat, safe surface where it can be easily accessed and handled.
- (3) Unscrew the screws on the front panel to extract the tray and access the hard disk.

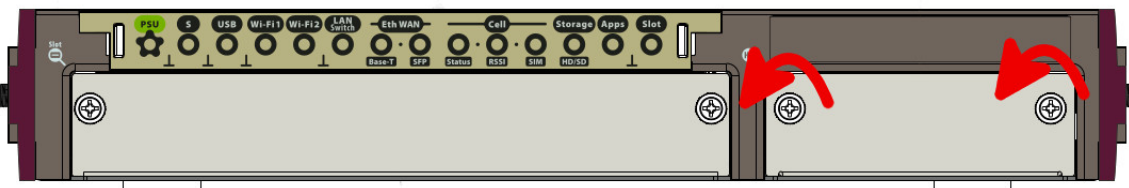

Fig. 32: Unscrewing the screws from the front panel tray

- (4) Once unscrewed, pull out the tray from the front panel slot.

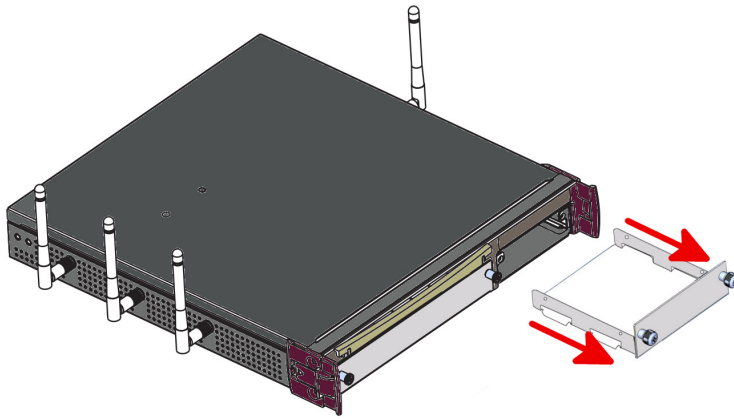

Fig. 33: Extracting the tray from the front panel

- (5) If the disk is attached, skip to the next step. If not, place the hard disk in the correct position after having extracted the tray. Then secure the hard disk using the appropriate 4 screws without damaging it during the tightening process (red arrows).

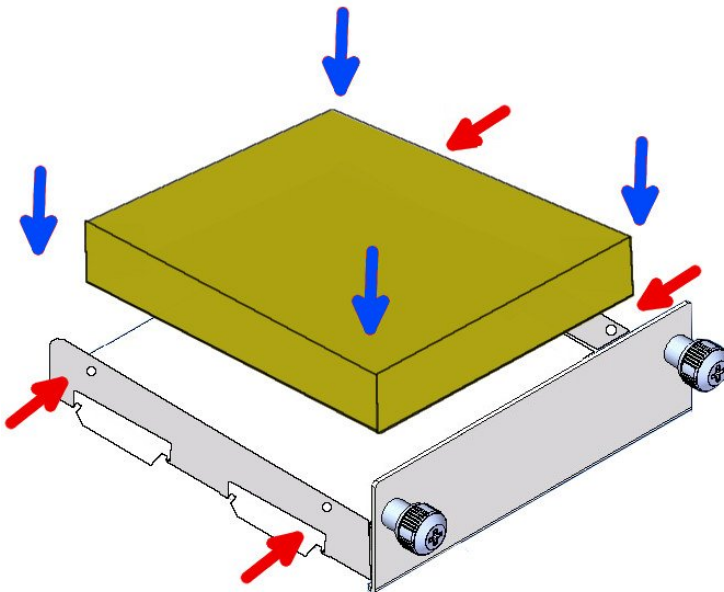

Fig. 34: Placing the hard disk

- (6) Finally, insert the tray into the device once again using the slot guides.

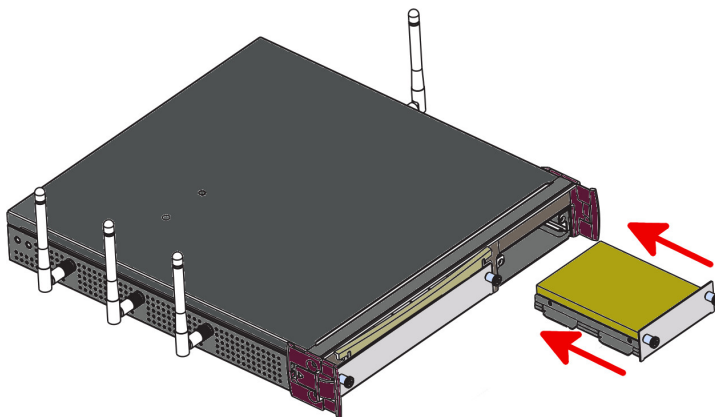

Fig. 35: Inserting the hard disk

- (7) Screw the tray to the device.



Fig. 36: Screw the tray to the front panel

- (8) Connect the equipment as indicated in section 3.5.1.1 "Connecting". Connect the terminal to the console and check that the device detects the hard disk.

3.9.2 Procedure to install a flash memory expansion SD

To install an SD card, insert it into the SD tray as shown in the following figure:

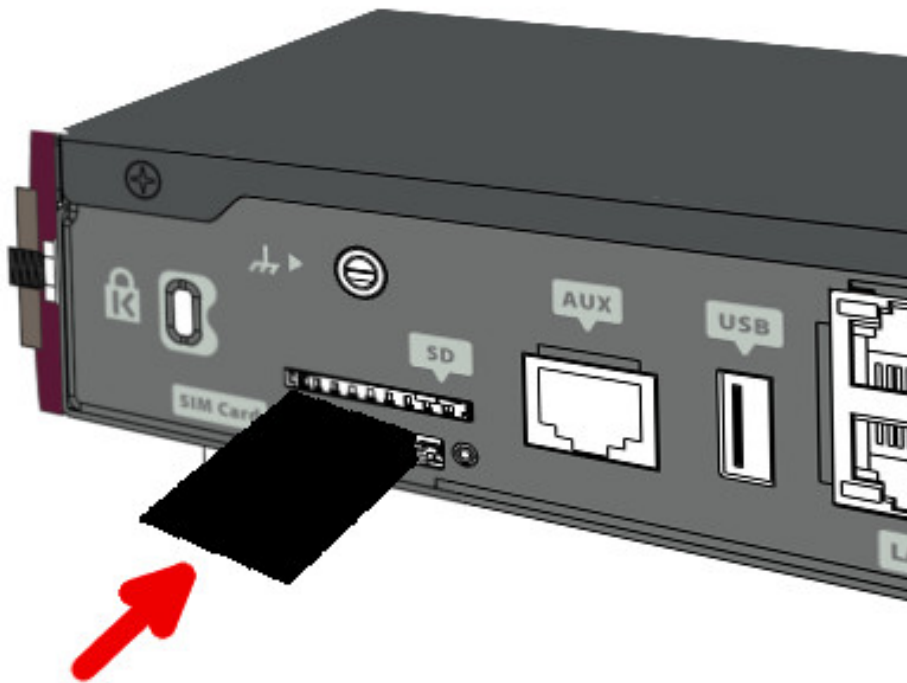





Fig. 37: Inserting SD card



Chapter 4 Compliance

4.1 Manufacturer information

<i>Brand</i>	bintec
<i>Manufacturer</i>	bintec elmeg
<i>Country</i>	Germany
<i>Postal Address</i>	Suedwestpark 94 90449 Nuremberg Germany
<i>International Phone</i>	+49 - 911 - 9673 0

4.2 Safety warnings

	<p>The electric current in power cables and communication cables is dangerous. To prevent electric shocks, before installing, handling or opening the equipment covers, connect and disconnect the cables following the steps set forth in <i>Connecting</i> on page 14 and <i>Disconnecting</i> on page 14.</p>
	<p>Der elektrische Strom in Strom-, Telefon- und Datenkabeln ist gefährlich. Um Elektroschocks zu vermeiden, trennen Sie vor der Installation, der Bedienung oder dem Öffnen des Geräts die Kabel wie in den Abschnitten Verbinden und Trennen beschrieben.</p>
	<p>La tensión eléctrica de los cables de alimentación es peligrosa. Para evitar descargas, antes de instalar, mover o abrir las cubiertas de este equipo, conecte y desconecte los cables siguiendo el orden que se detalla en los apartados "Conectar" y "Desconectar".</p>
	<p>All interconnected communication devices should be plugged to THE SAME GROUNDED POWER OUTLET, which should, at the same time, be of good quality (lower than 10 ohms).</p> <p>Whether the workplace is provided with an uninterrupted power supply system (UPS), regulated supply or it is independent from the rest (such as lighting, etc.); it is highly recommended that all data devices should be connected to the same power source. This will avoid operating and premature aging problems of drivers and other components.</p>
	<p>Alle miteinander verbundenen Kommunikationsgeräte sollten mit der gleichen geerdeten Stromversorgung verbunden werden. Diese sollte von hoher Qualität sein (niedriger als 10 Ohm).</p> <p>Unabhängig davon, ob der Arbeitsplatz über eine unterbrechungsfreie Stromversorgung (UPS) oder eine geregelte Versorgung verfügt oder unabhängig von der weitere Installation (z. B. Licht) ist – es wird dringend empfohlen, alle Geräte an die gleiche Spannungsversorgung anzuschließen. Dies beugt Problemen im Betrieb sowie Problemen der vorzeitigen Alterung von Komponenten vor.</p>
	<p>Todos los equipos de comunicaciones interconectados deberán estar unidos a UNA MISMA TOMA DE TIERRA de buena calidad (inferior a 10 ohmios).</p> <p>Si la instalación está dotada de un Sistema de Alimentación Ininterrumpida (SAI), alimentación estabilizada, o bien es independiente del resto (alumbrado, etc.), conecte todos los equipos de comunicaciones a la misma fuente de alimentación. De esta forma se evitarán problemas de funcionamiento y envejecimiento prematuro de drivers y demás componentes.</p>
	<p>Never install the SIM cards when the device is switched on.</p> <p>Always disconnect the device from the main power supply before installing the SIM cards.</p> <p>Always disconnect the device before removing the casing to access the trays.</p> <p>When inserting the SIM cards, please protect yourself against electrostatic discharges (ESD).</p> <p>Do not touch the SIM card connectors.</p>
	<p>Installieren Sie keine SIM-Karten, solange das Gerät eingeschaltet ist.</p> <p>Trennen Sie das Gerät immer von der Stromversorgung, bevor Sie eine SIM-Karte installieren.</p> <p>Trennen Sie das Gerät immer von der Stromversorgung, bevor Sie das Gehäuse für einen</p>

	<p>Zugang zu den SIM-Halterungen öffnen.</p> <p>Schützen Sie sich gegen elektrostatische Entladung (ESD), wenn Sie eine SIM-Karte installieren.</p> <p>Berühren Sie die SIM-Karten-Kontakte nicht.</p>
	<p>No instale nunca las tarjetas SIM con el equipo encendido.</p> <p>Desconecte siempre el equipo de la red antes de instalar las tarjetas SIM.</p> <p>Desconecte siempre el equipo antes de desmontar la carcasa para acceder a las bandejas.</p> <p>Al insertar las tarjetas SIM, protéjase contra descargas electroestáticas (ESD).</p> <p>No toque los conectores de las tarjetas SIM.</p>
	<p>The equipment is intended to be installed by Service Personnel and only handled by qualified personnel. If not, the device may be damaged and malfunction.</p>
	<p>Das Gerät ist für eine Montage durch Servicepersonal ausgelegt und darf nur von qualifiziertem Personal gehandhabt werden. Andernfalls kann es zur Beschädigung des Geräts und zu Fehlfunktionen kommen</p>
	<p>El equipo está diseñado para ser instalado por personal del servicio técnico y su manejo debe realizarlo personal cualificado. De lo contrario, el equipo puede resultar dañado y quedar inservible.</p>
	<p>The equipment must be used with the power supply provided by the manufacturer.</p>
	<p>Das Gerät muss mit dem vom Hersteller gelieferten Netzteil betrieben werden.</p>
	<p>El equipo debe ser usado con la fuente de alimentación proporcionada por el fabricante.</p>
	<p>Laser Radiation. Do not view directly with optical instruments. CLASS 1 LASER PRODUCT</p> <p>SFP modules to be installed in the card socket should be class 1 devices complying with standard IEC/EN 60825-1:2007</p>
	<p>Laserstrahlung. Nicht direkt mit optischen Instrumenten hineinsehen. LASERPRODUKT DER KLASSE 1</p> <p>SFP-Module, die im Kartenschacht installiert werden sollen, sollten Klasse-1-Geräte in Übereinstimmung mit IEC/EN 60825-1:2007 sein.</p>
	<p>Radiación laser. No mirar directamente con instrumentos ópticos. Producto LASER CLASE 1.</p> <p>Los módulos SFP que se instalen en el socket de la tarjeta deben ser dispositivos de CLASE 1 de acuerdo con la norma IEC/EN 60825-1:2007</p>

4.3 WEEE information



The crossed-out wheeled bin symbol indicates that the device must be disposed of separately from normal domestic waste at the end of its useful service life. Please use an appropriate waste disposal facility.

Das auf dem Gerät befindliche Symbol mit dem durchgekreuzten Müllcontainer bedeutet, dass das Gerät am Ende der Nutzungsdauer bei den hierfür vorgesehenen Entsorgungsstellen getrennt vom normalen Hausmüll zu entsorgen ist.

El símbolo del contenedor con la cruz, que se encuentra en el aparato, significa que cuando el equipo haya llegado al final de su vida útil, deberá ser llevado a los centros de recogida previstos, y que su tratamiento debe estar separado del de los residuos urbanos.

4.4 REACH

In compliance with the REACH Candidate List, the delivered product and product packaging do not contain chemical substances above a concentration limit of 0.1% weight by weight (w/w). This declaration will be updated whenever changes occur or other chemical substances are added to the REACH Candidate List. Information is currently provided to consumers upon request.

4.5 PSU energy efficiency

According to Commission Regulation (EU) 2019/1782 laying down ecodesign requirements for external power supplies pursuant to Directive 2009/125/EC of the European Parliament and of the Council and repealing Commission Regulation (EC) No 278/2009, the instruction manuals for end-users shall include the following information:

<i>Model</i>	DA-60N12
<i>Manufacturer Name</i>	ASIAN POWER DEVICES INC. (APD)
<i>Manufacturer Address</i>	NO.5 LANE 83. LUNG-SOU ST, TAO-YUAN CITY, TAIWAN R.O.C.
<i>Input Voltage</i>	100-240 Vac
<i>Input AC frequency</i>	50-60 Hz
<i>Output voltage</i>	12.0 V
<i>Output current</i>	5.0 A
<i>Output power</i>	60.0 W
<i>Average active efficiency</i>	88.3%
<i>Efficiency at low load (10%)</i>	87.2%
<i>No-load power consumption</i>	0.12 W

4.6 EC declaration of conformity

English (EN)	<p>Hereby, bintec elmeg declares that radio equipment RM5000 complies with:</p> <p>Directive 2014/53/EU (RED)</p> <p>Directive 2009/125/EC (ErP)</p> <p>Directive 2011/65/EU (RoHS)</p> <p>of the European Parliament and of the Council.</p>
German (DE) Deutsch	<p>Hiermit erklärt bintec elmeg die Übereinstimmung des Geräts RM5000 mit:</p> <p>Richtlinie 2014/53/EU (RED)</p> <p>Richtlinie 2009/125/EG (ErP)</p> <p>Richtlinie 2011/65/EU (RoHS)</p> <p>des Europäischen Parlaments.</p>
Spanish (ES) Español	<p>Por la presente, bintec elmeg declara que el tipo de equipo radioeléctrico RM5000 es conforme con:</p> <p>Directiva 2014/53/UE (RED)</p> <p>Directiva 2009/125/CE (ErP)</p> <p>Directiva 2011/65/UE (RoHS)</p> <p>del Parlamento Europeo y del Consejo.</p>

The EC declaration of conformity and additional product documentation can be accessed here:

<http://www.bintec-elmeg.com/conformity>

4.7 CE marking

This equipment is in conformity with the CE procedures and marking.



4.8 Laser product



Use only trained and qualified personnel to install or replace this device

Chose SFP+ transceivers that meet the following regulations

- Class 1
- IEC/EN60825-1:2007 2nd edition or later, European standard
- FCC 21 CFR chapter 1, subchapter J (in accordance with FDA and CDRH requirements)
- Application of CE marking in accordance with the 2014/30/EU EMC and the 2014/35/EU Low Voltage Directives
- UL and/or CSA registered component for North America
- 47 CFR Part 15, Class A

4.9 National restrictions

In accordance with Article 10 of 2014/53/EU, we inform you that, for authorization purposes, national restrictions and requirements may apply. These can change with time. bintec elmeg recommends that you check with local authorities for the latest status of national regulations.

This product is supplied with antennas in order to fulfill local regulations. Do not choose other antennas. To comply with power limits and RF exposure requirements, the antennas used for this transmitter must be installed in such a way that they are always separated from nearby persons by a minimum distance of at least 25 cm.

4.10 Operating frequency

To find out more about operating frequencies and the maximum radio-frequency power transmitted in the frequency bands in which the radio equipment operates, see appendix *RF WAN specifications* on page 40 and *WI-FI specifications* on page 41.

Appendix A Technical Information

A.1 Troubleshooting

The following table can help you solve problems when installing the device. If you cannot resolve the issue, please contact your dealer for more information.

Symptom	Solution
No LEDs light up on the router.	Check the power supply to the router (power source, ON/OFF switch, main power outlet).
You have forgotten the router's access password.	Ignore the configuration through the RST button (as explained in the relevant section).
The <i>LAN switch</i> LED never lights up in green.	Check the Ethernet cable and the connection to the network. Check the appropriate license is available for use.
The <i>Eth WAN</i> LED never lights up in green.	Check the Ethernet cable and the connection to the network.
The <i>Wi-Fi</i> LED never lights up in green.	Check the router configuration and that of the remote station(s). Check the appropriate license is available for use.
The <i>USB</i> LED never lights up in green.	Check that the device inserted in the USB connector is supported by the router. Please check the bintec website http://www.bintec-elmeg.com for a list of supported 3G USB modems. Check the appropriate license is available for use.

A.2 Updating the software

The **RM5000** router can be updated to new versions. Please contact your distributor for further details on new releases.

There are several ways to update a bintec router. For further information, please see manual: "bintec *Dm748-I Software Updating*".

The software required to update bintec routers is supplied in a format known as **distribution**. This consists of a single file containing all the files needed to update your device, as well as in-depth information on the contents of the files.

A.3 Connecting to the device

A.3.1 Connecting using the local console (Aux connector)

The **RM5000** router has a RJ45 female connector on the front panel, known as **Aux**, which provides access to the device's local console.

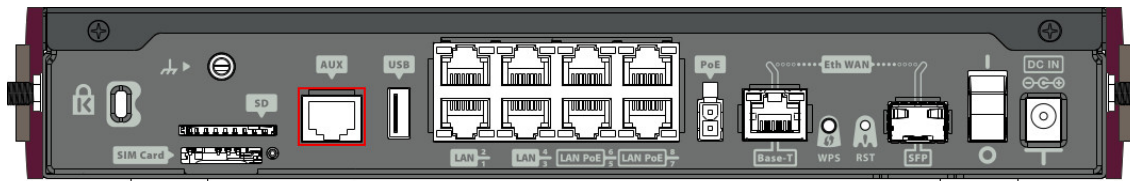

Fig. 40: **Aux Connector**

To configure this, you must connect the **Aux** port to an asynchronous terminal (or to a PC with terminal emulation).

Note

The configuration for the terminal must be:

- Speed: 9600 bps.
- Eight data bits.
- One stop bit.
- No parity bit.
- No type of flow control.

Connection to the configuration port can be carried out using the the RJ45 connector cable, supplied with the device, and an RJ45 female-DB9 female adaptor (also provided).

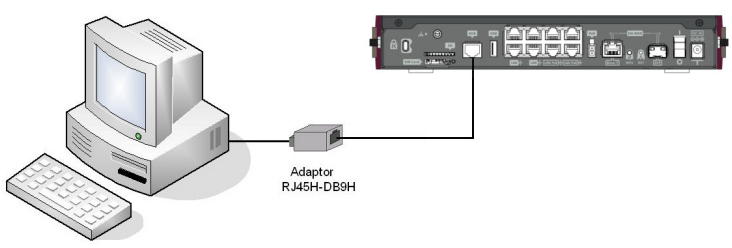

Fig. 41: **Connecting for Configuration**

A.4 Connectors

A.4.1 LAN connector (switch)

RJ45 LAN	RJ45 PIN	FE Signals	GE Signals
	1	BI-DA+ [PoE+]	BI-DA+
	2	BI-DA- [PoE+]	BI-DA-
	3	BI-DB+ [PoE-]	BI-DB+
	4	--	BI-DC+
	5	--	BI-DC-
	6	BI-DB- [PoE-]	BI-DB-
	7	--	BI-DD+
	8	--	BI-DD-

A.4.2 WAN Base-T connector

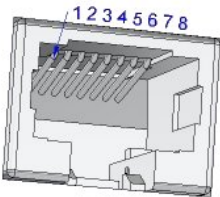
RJ45 WAN	RJ45 PIN	FE Signals	GE Signals
	1	BI-DA+	BI-DA+
	2	BI-DA-	BI-DA-
	3	BI-DB+	BI-DB+
	4	--	BI-DC+
	5	--	BI-DC-
	6	BI-DB-	BI-DB-
	7	--	BI-DD+
	8	--	BI-DD-

A.4.3 WAN SFP connector

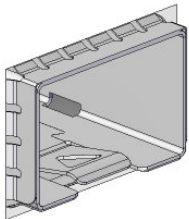
SFP	
	Standard SFP connector

A.4.4 WWAN connector

SMA Female	PIN	ANT
	Internal	RF in/out
	External	GND

A.4.5 WLAN connector

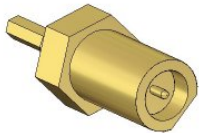
SMA-RP Female	PIN	ANT
	Internal	RF in/out
	External	GND

A.4.6 USB connector

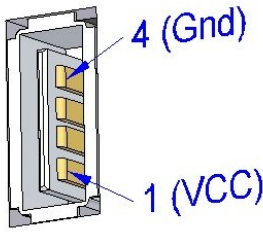
USB Type A	PIN	USB
	1	VCC
	2	DATA-
	3	DATA+
	4	GND
	Shell	Shield

A.4.7 Configuration connector

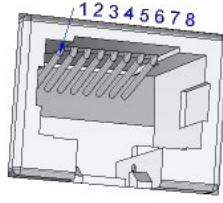
RJ45 CONFIGURATION	RJ45 PIN	CONF
	1	--
	2	RxD
	3	GND
	4	--
	5	--
	6	GND
	7	TxD
	8	--

A.4.8 Power supply connector

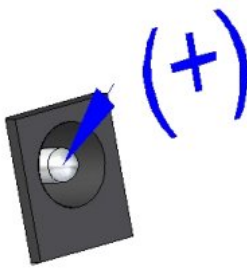
Jack 5.5/2.5mm	PIN
	Internal -> POSITIVE
	External -> NEGATIVE

A.5 Technical specifications

A.5.1 Hardware architecture

PROCESSORS	Freescale QorIQ.
MEMORY	1 Gbyte in SDRAM.
STORAGE UNIT	FLASH Memory (32 Mbytes).

A.5.2 LAN interface

PROTOCOLS	Ethernet (802.3).
PORTS	8 port switch managed with MDI/MDX auto-detection.
SPEED	10/100/1000 Mbps (Base-T).
CONNECTOR	RJ45 female.

A.5.3 WAN Base-T interface

STANDARDS	Ethernet (802.3).
SPEED	10/100/1000 Mbps (Base-T).
CONNECTOR	RJ45 female.

A.5.4 WAN SFP interface

STANDARDS	802.1Q (VLAN). 1000-Base-X.
SPEED	1000 Mbps full duplex.
TYPES	LX/LH (single mode 1310 nm). SX (multi-mode 850 nm). ZX (single mode 1550 nm).
CONNECTOR	Standard SFP connector.

A.5.5 Wireless WAN interface

<p>WWAN Standard/Bands</p>	<p>MC7455:</p> <ul style="list-style-type: none"> • LTE: B1-B5, B7, B12, B13, B17, B20, B25, B26, B29, B30, B41 • WCDMA: B1, B2, B3, B4, B5, B8 <p>MC7430:</p> <ul style="list-style-type: none"> • LTE: B1, B3, B5, B7, B8, B18, B19, B21, B28, B38-B41 • WCDMA: B1, B5, B6, B8, B9, B19 • TD-SCDMA: B39 <p>MC7304:</p> <ul style="list-style-type: none"> • LTE: B1, B3, B7, B8, B20 • WCDMA: B1, B2, B5, B8 • GSM/GPRS/EDGE: Quad-band <p>MC7354:</p> <ul style="list-style-type: none"> • LTE: B2, B4, B5, B13, B17, B25 • WCDMA: B1, B2, B4, B5, B8 • CDMA 1xRTT/EV-DO Rev A: BC0, BC1, BC10 • GSM/GPRS/EDGE: Quad-band
<p>Speed (DL/UL)</p>	<p>MC7455:</p> <ul style="list-style-type: none"> • LTE Cat 6. 150Mbps/50Mbps • HSPA+ Cat 24/6: 42Mbps/5.76Mbps <p>MC7430:</p> <ul style="list-style-type: none"> • LTE Cat 6. 150Mbps/50Mbps • HSPA+ Cat 24/6: 42Mbps/5.76Mbps <p>MC7304:</p> <ul style="list-style-type: none"> • LTE Cat 3. 100Mbps/50Mbps • HSPA+ Cat 24/6: 42Mbps/5.76Mbps • EDGE: 236Kbps <p>MC7354:</p> <ul style="list-style-type: none"> • LLTE Cat 3. 100Mbps/50Mbps • HSPA+ Cat 24/6: 42Mbps/5.76Mbps • CDMA 1xRTT: 153Kbps, EV-DO: 3.1Mbps/1.8Mbps • EDGE: 236Kbps
<p>CONNECTOR</p>	<p>Up to eight type SMA female connectors.</p>
<p>SIM Slots</p>	<p>4 Mini-SIM (2FF) ISO/IEC 7810:2003, ID-000 (1.8V / 3V).</p>

A.5.6 Wireless LAN interface

WLAN standards	IEEE 802.11a/b/g/n.
CONNECTOR	Up to eight SMA-RP female connectors.
Frequency range	2.4 GHz: 2412 ~ 2472 MHz. 5 GHz: 5180 ~ 5825 MHz.
WLAN modes	2,4 GHz Operation: 802.11b only; 802.11g only; 802.11b/g; 802.11b/g/n; 802.11g/n. 5 GHz Operation: 802.11a only; 802.11a/n; 802.11n.
Modulation Techniques	OFDM: BPSK, QPSK, DBPSK, DQPSK, 16-QAM, 64-QAM, 256-QAM.
Automatic Rate Selection (ARS)	Available.
Transmission rate	Automatic.
Data rates	802.11a: 6~54 Mbps. 802.11b: 1~11 Mbps. 802.11g: 6~54 Mbps. 802.11n (HT20): MCS0 ~ MCS15. 802.11n (HT40): MCS0 ~ MCS15.
Data rates for 802.11n, Long Guard (800ns), 20 MHz	MCS0 6,5 Mbps; MSC1 13 Mbps; MCS2 19,5 Mbps; MCS3 26 Mbps; MCS4 39 Mbps; MSC5 52 Mbps; MCS6 58,5 Mbps; MCS7 65 Mbps; MCS8 13 Mbps; MCS9 26 Mbps; MCS10 39 Mbps; MCS11 52 Mbps; MCS12 78 Mbps; MCS13 104 Mbps; MCS14 117 Mbps; MCS15 130 Mbps.
Data rates for 802.11n, Short Guard (400ns), 20 MHz	MCS0 7,2 Mbps; MSC1 14,4 Mbps; MCS2 21,7 Mbps; MCS3 28,9 Mbps; MCS4 43,3 Mbps; MSC5 57,8 Mbps; MCS6 121,5 Mbps; MCS7 135 Mbps; MCS8 27 Mbps; MCS9 54 Mbps; MCS10 81 Mbps; MCS11 108 Mbps; MCS12 162 Mbps; MCS13 216 Mbps; MCS14 243 Mbps; MCS15 270 Mbps.
Data rates for 802.11n, Long Guard (800ns), 40 MHz	MCS0 13,5 Mbps; MSC1 27 Mbps; MCS2 40,5 Mbps; MCS3 54 Mbps; MCS4 81 Mbps; MSC5 108 Mbps; MCS6 121,5 Mbps; MCS7 135 Mbps; MCS8 27 Mbps; MCS9 54 Mbps; MCS10 81 Mbps; MCS11 108 Mbps; MCS12 162 Mbps; MCS13 216 Mbps; MCS14 243 Mbps; MCS15 270 Mbps.
Data rates for 802.11n, Short Guard (400ns), 20 MHz	MCS0 15 Mbps; MSC1 30 Mbps; MCS2 45 Mbps; MCS3 60 Mbps; MCS4 90 Mbps; MSC5 120 Mbps; MCS6 135 Mbps; MCS7 150 Mbps.
Output power limitation (without antenna gain)	Adjustable in dBm. Maximal power varies depending on data rate, frequency band and country setting.
Output Power	<i>Note: The maximum RF power setting will vary according to specified country regulations.</i> 802.11a: 5.150~5.350 GHz Band: <ul style="list-style-type: none"> • +16 dBm at 6~24 Mbps • +14 dBm at 48 Mbps

- +13 dBm at 54 Mbps

5.470~5.725 GHz Band:

- +16 dBm at 6~24 Mbps
- +13 dBm at 48 Mbps
- +12 dBm at 54 Mbps

5.725~5.825 GHz Band:

- +15 dBm 6~24 Mbps
- +12dBm at 48 Mbps
- +11 dBm at 54 Mbps

802.11b: 18 dBm at 1, 2, 5.5, 11Mbps

802.11g:

- +19 dBm at 6 ~12, 18, 24 Mbps
- +18 dBm at 36, 48, 54 Mbps

802.11n @2.4 GHz

HT20

- +18dBm at MCS0/8, MCS1/9, MCS3/11, MCS4, MCS5
- +16dBm at MCS6, MCS7

HT40

- +18dBm at MCS0/8, MCS1/9, MCS3/11, MCS4
- +17dBm at MCS5
- +16dBm at MCS6
- +15dBm at MCS7

802.11n @ 5 GHz

HT20

5.150~5.350 GHz Band:

- +15dBm at MCS0/8, 1/9, 2/10, 3/11, 4/12, 5/13, MCS6/14
- +12dBm at MCS7/15

5.470~5.725 GHz Band:

- +15dBm at MCS0/8, 1/9, 2/10, 3/11, 4/12, 5/13, MCS6/14
- +12dBm at MCS7/15

5.725~5.825 GHz Band:

- +14dBm at MCS0/8, 1/9, 2/10, 3/11, 4/12, 5/13
- +12dBm at MCS6/14
- +10dBm at MCS7/15

HT40

5.150~5.350 GHz Band:

- +13~15dBm at MCS0/8, 1/9, 2/10, 3/11, 4/12, 5/13, MCS6/14
- +11~13dBm at MCS7/15

5.470~5.725 GHz Band:

- +13~15dBm at MCS0/8, 1/9, 2/10, 3/11, 4/12, 5/13, MCS6/14

	<ul style="list-style-type: none"> • +10~12dBm at MCS7/15 5.725~5.825 GHz Band: <ul style="list-style-type: none"> • +12~15dBm at MCS0/8, 1/9, 2/10, 3/11, 4/12, 5/13, MCS6/14 • +10~12dBm at MCS7/15
Bandwidth (802.11n)	20 MHz. 40 MHz (bundling two adjoining 20 MHz channels into one 40 MHz channel).

A.5.7 USB interface

3G USB MODEMS	Please visit the bintec website http://www.bintec-elmeg.com for a list of supported 3G USB modems.
SPEED	The interface complies with the USB 2.0 (480 Mbps) standard; the end speed depends on the 3G USB modem used.
CONNECTOR	USB Type A.

A.5.8 Configuration interface

LOCAL TERMINAL	RS-232 9600-8-N-1 without flow control.
CONNECTOR	RJ45 female on the device front panel.

A.5.9 Power supply

INPUT VOLTAGE	+12V DC.
INPUT CURRENT	1200 mA.
CONNECTOR	Jack 5.5/2.5 mm.

A.5.10 Dimensions and weight

TYPE	Desktop / chassis for a 1 U high rack mount enclosure.
LENGTH x WIDTH x HEIGHT	245 x 210 x 45 mm.
WEIGHT	1.4 kg.

A.5.11 Environmental specifications

TEMPERATURE	OPERATING NORMALLY: 0 °C to 40 °C. STORED: -25 °C to 70 °C.
RELATIVE HUMIDITY	On: 5 % to 90 %.

Appendix B Radio Information

This section includes some of the European radio frequencies that comply with CE regulatory requirements. Customers may obtain additional country-specific bands upon request.

B.1 RF WAN specifications

The LTE/WCDMA/GSM features are provided by the Sierra Wireless modules. The module types installed depend on the router model.

Technology: LTE by MC7455.

Bands	Frequencies	Conducted Transmit Power
Band 1	Tx: 1920-1980 MHz Rx: 2110-2170 MHz	+23 dBm ± 1 dB
Band 3	Tx: 1710-1785 MHz Rx: 1805-1880 MHz	+23 dBm ± 1 dB
Band 7	Tx: 2500-2570 MHz Rx: 2620-2690 MHz	+22 dBm ± 1 dB
Band 20	Tx: 832-862 MHz Rx: 791-821 MHz	+23 dBm ± 1 dB

Technology: LTE provided by MC7430

Bands	Frequencies	Conducted Transmit Power
Band 1	Tx: 1920-1980 MHz Rx: 2110-2170 MHz	+23 dBm ± 1 dB
Band 3	Tx: 1710-1785 MHz Rx: 1805-1880 MHz	+23 dBm ± 1 dB
Band 7	Tx: 2500-2570 MHz Rx: 2620-2690 MHz	+22 dBm ± 1 dB

Technology: UMTS(WCDMA)/ HSDPA/ HSUPA/ HSPA+/ DC-HSPA+ by MC7455

Bands	Frequencies	Conducted Transmit Power
Band 1	Tx: 1920-1980 MHz Rx: 2110-2170 MHz	+23 dBm ± 1 dB
Band 3	Tx: 170-1785 MHz Rx: 1805-1880 MHz	+23 dBm ± 1 dB
Band 8	Tx: 880-915 MHz Rx: 925-960 MHz	+23 dBm ± 1 dB

Technology: UMTS(WCDMA)/ HSDPA/ HSUPA/ HSPA+/ DC-HSPA+ by MC7430

Bands	Frequencies	Conducted Transmit Power
Band 1	Tx: 1920–1980 MHz Rx: 2110–2170 MHz	+23 dBm ± 1 dB
Band 8	Tx: 880–915 MHz Rx: 925–960 MHz	+23 dBm ± 1 dB

B.2 WI-FI specifications

The WMCND03TD module provides Wifi Radio communications, in accordance with standards 802.11a/b/g/n.

This product is supplied without any antennas. The operator must make sure that the antennas of his/her picking comply with the local regulations.

Frequency Range	<p>802.11a, 802.11n @ 5 GHz</p> <ul style="list-style-type: none"> • USA & Canada: 5.15 ~ 5.35GHz. , 5.47 ~ 5.725GHz and 5.725~5.850 GHz • Europe: 5.15 ~ 5.35GHz and 5.47 ~ 5.725GHz GHz • Japan: 5.15 ~ 5.35GHz and 5.47 ~ 5.725GHz GHz • China: 5.725 ~ 5.850GHz <p>802.11b</p> <ul style="list-style-type: none"> • 2400 ~2497 MHz <p>802.11g</p> <ul style="list-style-type: none"> • 2400 ~2497 MHz <p>802.11n @ 2.4 GHz</p> <ul style="list-style-type: none"> • 2.4 ~2.5 GHz
Operating	<p>802.11a/n:</p> <ul style="list-style-type: none"> • USA/Canada: 24 non-overlapping channels. • Major Europe Countries: 19 non-overlapping channels. • Japan: 19 non-overlapping channels. • China: 5 non-overlapping channels. <p>802.11b:</p> <ul style="list-style-type: none"> • USA: 11 channels. • Europe Countries: 13 channels. • Japan: 14 channels. <p>802.11g/n:</p> <ul style="list-style-type: none"> • USA: 11 channels. • Europe Countries: 13 channels. • Japan: 13 channels.
Output Power. (tolerance ± 2 dB)	<p><i>Note: The maximum RF power setting will vary according to country-specific regulations.</i></p> <p>802.11a:</p>

5.150~5.350 GHz Band:

- +16 dBm at 6~24 Mbps
- +14 dBm at 48 Mbps
- +13 dBm at 54 Mbps

5.470~5.725 GHz Band:

- +16 dBm at 6~24 Mbps
- +13 dBm at 48 Mbps
- +12 dBm at 54 Mbps

5.725~5.825 GHz Band:

- +15 dBm 6~24 Mbps
- +12dBm at 48 Mbps
- +11 dBm at 54 Mbps

802.11b: 18 dBm at 1, 2, 5.5, 11Mbps

802.11g:

- +19 dBm at 6 ~12, 18, 24 Mbps
- +18 dBm at 36, 48, 54 Mbps

802.11n @2.4 GHz*HT20*

- +18dBm at MCS0/8, MCS1/9, MCS3/11, MCS4, MCS5
- +16dBm at MCS6, MCS7

HT40

- +18dBm at MCS0/8, MCS1/9, MCS3/11, MCS4
- +17dBm at MCS5
- +16dBm at MCS6
- +15dBm at MCS7

802.11n @ 5 GHz*HT20*

5.150~5.350 GHz Band:

- +15dBm at MCS0/8, 1/9, 2/10, 3/11, 4/12, 5/13, MCS6/14
- +12dBm at MCS7/15

5.470~5.725 GHz Band:

- +15dBm at MCS0/8, 1/9, 2/10, 3/11, 4/12, 5/13, MCS6/14
- +12dBm at MCS7/15

5.725~5.825 GHz Band:

- +14dBm at MCS0/8, 1/9, 2/10, 3/11, 4/12, 5/13
- +12dBm at MCS6/14
- +10dBm at MCS7/15

HT40

5.150~5.350 GHz Band:

- +13~15dBm at MCS0/8, 1/9, 2/10, 3/11, 4/12, 5/13, MCS6/14

- +11~13dBm at MCS7/15

5.470~5.725 GHz Band:

- +13~15dBm at MCS0/8, 1/9, 2/10, 3/11, 4/12, 5/13, MCS6/14
- +10~12dBm at MCS7/15

5.725~5.825 GHz Band:

- +12~15dBm at MCS0/8 , 1/9, 2/10, 3/11, 4/12, 5/13, MCS6/14
- +10~12dBm at MCS7/15