

QUICK INSTALL GUIDE

Copyright © February 25, 2005 Funkwerk Enterprise Communications GmbH
Bintec User's Guide - XGeneration
Version 1.2

Purpose This document is part of the user's guide to the installation and configuration of Bintec gateways running software release 7.1.14 or later. For up-to-the-minute information and instructions concerning the latest software release, you should always read our **Release Notes**, especially when carrying out a software update to a later release level. The latest **Release Notes** can be found at www.bintec.net.

Liability While every effort has been made to ensure the accuracy of all information in this manual, Funkwerk Enterprise Communications GmbH cannot assume liability to any party for any loss or damage caused by errors or omissions or by statements of any kind in this document and is only liable within the scope of its terms of sale and delivery.

The information in this manual is subject to change without notice. Additional information, changes and **Release Notes** for Bintec gateways can be found at www.bintec.net.

As multiprotocol gateways, Bintec gateways set up WAN connections in accordance with the system configuration. To prevent unintentional charges accumulating, the operation of the product should be carefully monitored. Funkwerk Enterprise Communications GmbH accepts no liability for loss of data, unintentional connection costs and damages resulting from unsupervised operation of the product.

Trademarks Bintec and the Bintec logo are registered trademarks of Funkwerk Enterprise Communications GmbH. Other product names and trademarks mentioned are usually the property of the respective companies and manufacturers.

Copyright All rights are reserved. No part of this publication may be reproduced or transmitted in any form or by any means – graphic, electronic, or mechanical – including photocopying, recording in any medium, taping, or storage in information retrieval systems, without the prior written permission of Funkwerk Enterprise Communications GmbH. Adaptation and especially translation of the document is inadmissible without the prior consent of Funkwerk Enterprise Communications GmbH.

Guidelines and standards Bintec gateways comply with the following guidelines and standards:

R&TTE Directive 1999/5/EG

CE marking for all EU countries and Switzerland

You will find detailed information in the Declarations of Conformity at www.bintec.net.

**How to reach Funkwerk
Enterprise Communications
GmbH**

Funkwerk Enterprise Communications GmbH Suedwestpark 94 D-90449 Nuremberg Germany Telephone: +49 180 300 9191 0 Fax: +49 180 300 9193 0 Internet: www.funkwerk-ec.com	Bintec France 6/8 Avenue de la Grande Lande F-33174 Gradignan France Telephone: +33 5 57 35 63 00 Fax: +33 5 56 89 14 05 Internet: www.bintec.fr
--	---



1	Introduction	3
2	Taking into Operation	5
2.1	Connections	5
2.2	Setting Up and Connecting	6
3	Configuration	9
3.1	In Advance of Configuration	10
3.1.1	Gathering Information	10
3.1.2	Configure the PC	12
3.1.3	Installing BRICKware	13
3.2	Configuring the Gateway	15
3.3	Testing the Configuration	17
4	Support Information	19



1 Introduction

Your XGeneration Gateway is extensively equipped for Internet access for both single users and small offices.

Essential system requirements:

- Windows 95, Windows 98, Windows ME, Windows NT 4.0, Windows 2000 or Windows XP
(The instructions on testing/installing the TCP/IP protocol and configuring the PC apply to Windows 2000 or Windows XP. For Windows 95, Windows 98, Windows ME or Windows NT 4.0, please see the instructions in the User's Guide **Basic Configuration Compact Routers**, which you will find on your Bintec **Companion CD** or can download from www.bintec.net.)
- Network card installed (Ethernet)
- CD-ROM drive
- Microsoft TCP/IP protocol installed (see "Checking the TCP/IP protocol" on page 12)
- High color display (more than 256 colors) for correct display of graphics

Companion CD The **Companion CD** enclosed in the delivery size contains all tools necessary for the configuration and management of your gateway.

This Quick Install Guide shows you how to set up a basic configuration for your **XGeneration** Gateway step by step using the **HTML Wizard**. Detailed knowledge of networking is not necessary. A detailed online help system gives you extra support.

The **BRICKware** includes helpful applications for the management of your gateway.

Congratulations on your new purchase and have fun!

2 Taking into Operation

The basic requirements for taking your **XGeneration** Gateway into operation are described below.

You can integrate your gateway into a local area network (LAN):

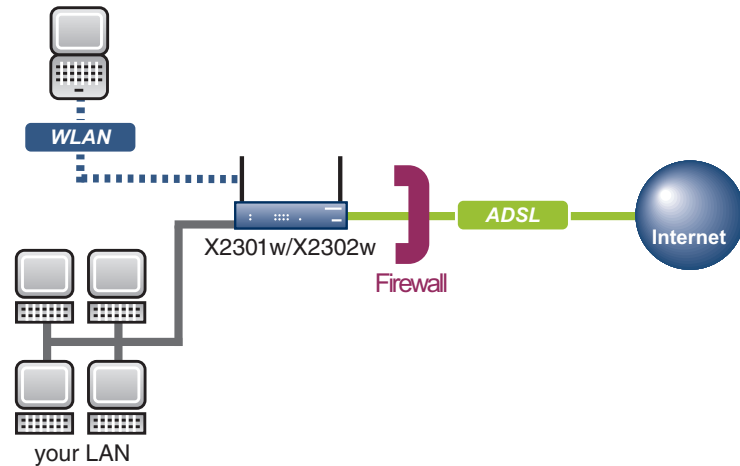

Figure 2-1: Basic scenario



Please read the safety precautions carefully before installing and taking your **XGeneration** Gateway into operation. These are supplied together with the gateway. The current version is also available at www.bintec.net.

2.1 Connections

All connections on **X2301**, **X23020**, **X2301w** and **X2302w** are located at the rear of the unit.

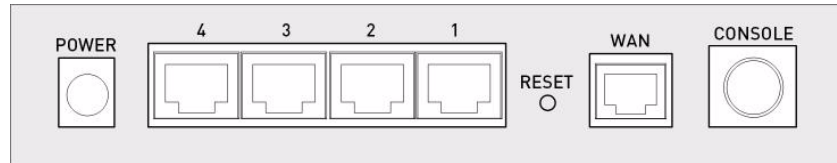
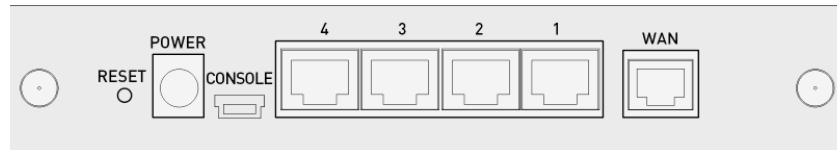
X2301 and X2302Figure 2-2: Rear of **X2301** and **X2302****X2301w and X2302w**Figure 2-3: Rear of **X2301w** and **X2302w**

2.2 Setting Up and Connecting

After you have carried out the following steps, the gateway is ready for configuration with the [HTML Wizard](#).

All you need for this is the cables supplied with the equipment. If you wish to set up more than one local network connection, you need further Ethernet cables.



Attention!

The use of the wrong mains adaptor may damage your gateway! Use only the mains adaptor supplied with the equipment!

Set up and connect the gateway in the following order:

1. Screw on the two provided external standard antennas to the respective RSMA connections.
2. Place your gateway on a firm, level base.
3. Orient the antenna.
4. Serial connection: Connect the serial port of your PC (COM1 or COM2) to the serial port of your gateway. Use only the serial cable supplied with the

equipment. This can be left out if you do not need a serial connection to the gateway.

5. **LAN:** Connect the first switch port (1) of your gateway to your LAN using the Ethernet cable supplied. The device detects automatically whether it is connected to a switch or directly to a PC.
6. **WAN:** Connect the WAN interface (WAN) of your gateway to your DSL socket at your splitter using the DSL cable supplied.
7. **Optional LAN:** Connect the remaining switch ports (2, 3 or 4) of your gateway to any other desired LAN interfaces using further Ethernet cables.
8. **Mains supply:** Connect your gateway to a mains socket using the mains adaptor supplied.

The gateway is now prepared for configuration using the **HTML Wizard**.

3 Configuration

The initial configuration of your gateway and the preparations are described below. On completion of configuration work your gateway is ready for operation in accordance with the configuration elements you have selected.

As preliminary preparation for the configuration, you should collect certain data and check whether the PC from which you wish to make the configuration meets the necessary requirements. You can also install **BRICKware**, which provides additional tools for working with your gateway. This installation is optional and not essential for the configuration or operation of the gateway.

Once you have made all the preparations you can configure your gateway. You may then need to adjust a few settings on your PC, after which you can finally check the configuration and operability of your gateway.

Preconfigured values of your gateway

Your **XGeneration** gateway is shipped with a predefined IP configuration:

- **IP ADDRESS:** 192.168.0.254
- **NETMASK:** 255.255.255.0.

In ex works state use the following user name and password to access your gateway for configuration:

- **USER NAME:** admin
- **PASSWORD:** bintec.



All Bintec gateways are shipped with the same user names and passwords. As long as the password remains unchanged, they are not protected against unauthorized use.

Change the passwords to prevent unauthorized access to your gateway! (See Bintec User's Guide chapter Access and Configuration.)

Software update

Your gateway is equipped with the latest system software version available for manufacturing. Newer versions of the software may be available in the meantime. How to check the current software version of your gateway and, if appli-

cable, carry out a software update is described in the **Bintec User's Guide** chapter **Gateway Management** (in the Basics section).

WLAN As WLAN uses the air as transmission medium, the transferred data can theoretically be intercepted and read by anyone with the respective means. Thus, safeguarding the radio link is to be paid special attention.

Follow the safety instructions for the WLAN configuration.

You can find information on how to secure your WLAN at www.wifi.org/OpenSection/index.asp.

3.1 In Advance of Configuration

Only a few steps are necessary to prepare the configuration of your gateway: gather some information for the basic configuration (optional for Internet access), configure the PC which is used to carry out the gateway configuration, and install the BRICKware.

3.1.1 Gathering Information

The essential information for basic configuration with the HTML Wizard is soon gathered, as no information is required that needs in-depth network knowledge. If applicable, you can use the example values.

Before you start the configuration, you should gather the data for the following purposes:

- Basic configuration
(obligatory if your gateway is in the ex works state)
- Internet access
(optional)

The following table shows examples of possible values for the necessary access data. You can fill in the table with your personal data under the heading "Your value", so that you can refer to these values later when needed.

If you configure a new network, you can use the given example values for IP addresses and netmask. If in doubt, ask your system administrator.

Basic configuration For the basic configuration of your gateway, you need information about your network environment:

Access data	Example	Your value
IP address of your gateway	<i>192.168.0.254</i>	
Netmask of your gateway	<i>255.255.255.0</i>	

Table 3-1: Basic information

Internet access If you want to configure an Internet access, you will need an Internet Service Provider (ISP). You receive your personal access data from your ISP. The terms used for the required access data may vary from provider to provider, but the type of information you need for dialing in is basically the same.

The following table lists the access data that your gateway needs for a DSL connection to the Internet.

Access data	Example	Your value
Provider name	<i>GoInternet</i>	
Protocol	<i>PPP over Ethernet (PPPoE)</i>	
Encapsulation	<i>bridge-no-fcs</i>	
VPI (Virtual Path Identifier)	<i>1</i>	
VCI (Virtual Circuit Identifier)	<i>32</i>	
Your user name	<i>MyName</i>	
Password	<i>TopSecret</i>	

Table 3-2: Data for Internet access

Some Internet Service Providers such as T-Online require additional information:

Access data	Example	Your value
T-Online number	081512345678	
Joint user account (other user code)	0001	

Table 3-3: Additional information for T-Online

3.1.2 Configure the PC

A number of conditions must be fulfilled at the PC with which you carry out the configuration, before you can reach your gateway over the network and configure it using the [HTML Wizard](#).

Make sure the TCP/IP protocol is installed before you start the configuration.

Then you must assign a fix IP address to the PC to be able to set up a connection to the gateway.

Checking the TCP/IP protocol

Proceed as follows to check whether you have installed the protocol:

1. Click **Settings → Network and Dial-up Connections** resp. **Control Panel → Network Connections** in the Start menu.
2. Double click **LAN Connection**.
3. Click **Properties** in the status window.
4. Look for **Internet Protocol (TCP/IP)** in the list of network components.

Installing the TCP/IP protocol

If you cannot find the entry **TCP/IP**, install the TCP/IP protocol as follows:

1. First click **Properties**, then **Install** in the status window of the **LAN Connection**.
2. Select the **Protocol** entry.
3. Click **Add**.
4. Select **Internet Protocol (TCP/IP)** and click **OK**.
5. Follow the instructions on the screen and finally restart your PC.

Assign PC an IP address

Assign your PC an IP address as follows:

1. Select **Internet Protocol (TCP/IP)** and click **Properties**.
2. Select **Use the following IP address** and enter an IP address.

Your PC should now fulfill all the conditions for the configuration of your gateway using the **HTML Wizard**.

Enter gateway IP address at PC

Continue by entering the IP address of your gateway into the PC configuration as follows:

3. Enter the IP address of your gateway into **Default gateway in Internet Protocol (TCP/IP) → Properties**.

If you do not use the preconfigured IP address of the gateway nor have yet defined one according to your network requirements, carry out the first steps of the gateway configuration. You can perform an automatic determination of a free IP address within your network. Enter the resulting IP address here (see [“Configuring the Gateway” on page 15](#)).

4. Enter the IP address of your gateway into **Use the following DNS server addresses**.
5. Click **OK**.
6. Close the dialog box with **OK**.

The PC now has an IP configuration and can access the Internet via the gateway.

3.1.3 Installing BRICKware

BRICKware contains a number of programs to help you when working with your gateway. The installation is optional.

You only need the **Companion CD** supplied with your gateway for the installation. Your PC should also fulfill the conditions stated in see [“Introduction” on page 3.](#)

Tool	Description
Activity Monitor	Activity Monitor provides a permanent overview of the interface status and the data traffic. The administrator has the password-protected option to selectively control individual interfaces and connections by a set of commands that allow him to, e.g., set up and clear connections or change a pre-configured Internet provider.
SNMP Manager	The SNMP Manager , provides simple access to all SNMP tables and SNMP system variables via a graphical user interface. The desired configuration part can be selected from a tree structure and then configured in the usual Windows-style dialog boxes.
Dime Tools	The Dime Tools are a set of tools for configuration, maintenance and diagnosis. They comprise a BootP server, a TFTP server, a Syslog Daemon and a Time Server.

Table 3-4: **BRICKware** tools

Proceed as follows to install the software:

1. Close all Windows programs on your PC.
2. Place your Bintec **Companion CD** in the CD-ROM drive of your PC. The Start window appears automatically after a short time. If the Start window does not open automatically, click your CD-ROM drive in Windows Explorer and double-click **setup.exe**. (For Unix systems: Open the file **index.htm** in your standard browser.)
3. Click **BRICKware** in the Add ons section. A new window opens. Here you can start the configuration or display descriptions of the individual **BRICKware** tools. Click the respective button to start the setup.
4. Specify the directory in which **BRICKware** should be installed.

5. Select your gateway, i.e. **X2301** or **X2302**.
6. Select the software components you wish to install.

The installed programs are available for use immediately after the installation of **BRICKware**. It is not usually necessary to restart the PC.

3.2 Configuring the Gateway

Your gateway can be configured quickly and easily with the **HTML Wizard**.



Note

If you have already created a configuration with the Wizard, the Wizard can use the preset values. You are informed about this possibility during configuration.

The configuration of your gateway is started as follows:

1. Select **Installation** on the Bintec **Companion CD** and click the button **Configure Gateway**.

2. Note the information on how to determine a free IP address for your gateway in the network. Click **Assign automatically...** or enter your defined IP address and netmask.
3. Start the configuration with **Finish**.

You can carry out the configuration in either Quick Mode or Advanced Mode. If you are unfamiliar with networking technologies, choose Quick Mode. Your gateway is ready for operation when you have completed the configuration.

You can select from the following configuration items:

- basic configuration
- Internet access

The basic configuration is essential if your gateway is still in the ex works state, as it integrates the gateway into your local network.

Proceed as follows:

1. Select the desired items and follow the instructions on the screen.
2. To be able to use your gateway in your local network, it may be necessary to make a few more settings on the PCs connected in the network.
You can set up Internet access over your gateway for all PCs in the same network as your gateway. To do this, you should configure all PCs as DHCP clients. Otherwise you must assign a fix IP address to each PC and define your **XGeneration** Gateway as default gateway and as DNS server (see [“Enter gateway IP address at PC” on page 13](#)).

The configuration of the gateway and its integration into your network are now completed.

WLAN The WLAN configuration is carried out via the **Setup Tool**.

Further gateway access options The predefined IP configuration (192.168.0.254/255.255.255.0) of your **XGeneration** Gateway enables simple access to further configuration options.

Enter *192.168.0.254/wizard* to start the HTML configuration assistant (**HTML Wizard**) with any current Web browser (java script must be activated).

The **HTML Setup Tool** can also be opened with any current Web browser (java script must be activated). Enter *192.168.0.254/setup* to start a Setup Tool session.

You can also start both configuration tools from the HTML status page of the gateway. To access the status page, just enter `192.168.0.254` in your Web browser.

Other means of access and configuration information are described in the chapter **Access and Configuration** of the **Bintec User's Guide** (as a part of the Basics section).

3.3 Testing the Configuration

You have completed the configuration of your gateway and can now test the connection in your LAN and to the Internet.

Carry out the following steps to test your gateway:

1. Remove the serial cable from your gateway if you no longer need the serial connection.
2. Test the connection to your gateway. Click **Run** in the Start menu and enter `ping`, followed by a space and the IP address of your gateway (`192.168.0.254`). A window appears with the response "Reply from...".
3. Test the Internet access by entering **`www.bintec.net`** in the Internet browser. The Bintec Internet site offers you the latest news, updates and documentation.



Incorrect configuration of the devices in your LAN may result in unwanted connections and increased charges! Monitor your gateway and make sure it does not set up unwanted connections (and charges). Watch the LEDs on your gateway (WAN LED; for meaning of LEDs see Bintec User's Guide chapter Technical Data) or use the Activity Monitor (see [BRICKware](#) for Windows).

4 Support Information

Contact numbers and addresses of the Bintec Support Center of Funkwerk Enterprise Communications GmbH:

Germany Available from monday till friday 9 a.m. - 5 p.m. (CET)
Switzerland
Austria

■ First Level Support:

– **Telephone: 00 800 7333 7333**

Free of charge within 6 weeks after purchase

(the telephone number is free of charge, only reachable from a conventional telephone network from Germany, Switzerland, Austria and France)

Please keep the hardware serial number of your device ready for verification of support authorization!

– **Telephone: 0190 – 85 10 68** (EUR 1,86/min. from a conventional telephone network only in Germany)

■ Second Level Support:

Telephone: +49 - 180 300 9191 550

Fax: +49 - 180 300 9191 599

E-Mail: hotline@funkwerk-ec.de

For further information on the Bintec support services please see www.bintec.net.

France Available during local normal trading hours.

■ First Level Support and Second Level Support:

Telephone: 08.90.71.05.71 (TTC EUR 0,15/min.)

E-Mail: support.france@funkwerk-ec.com

- Spain** Available during local normal trading hours.
- Portugal**
- First Level Support:
Telephone: + 34 - 91 658 7504
E-Mail: support.spain@funkwerk-ec.com
 - Second Level Support:
Telephone: +49 - 911 9673 1550 or +49 - 180 300 91 91 550
Fax: +49 - 911 9673 1599 or +49 - 180 300 9191 599
E-Mail: support@funkwerk-ec.com
- Italy** Available during local normal trading hours.
- First Level Support:
E-Mail: support.italy@funkwerk-ec.com
 - Second Level Support:
Telephone: +49 - 911 9673 1550 oder +49 - 180 300 91 91 550
Fax: +49 - 911 9673 1599 or +49 - 180 300 9191 599
E-Mail: support@funkwerk-ec.com
- Great Britain** Available from monday till friday 9 a.m. - 5 p.m. (CET)
- Second Level Support:
Telephone: +49 - 911 9673 1550 or +49 - 180 300 91 91 550
Fax: +49 - 911 9673 1599 or +49 - 180 300 9191 599
E-Mail: support@funkwerk-ec.com