



elmeg T240 elmeg T444

**Installation guide
English**

Declaration of conformity and CE mark



This device meets the requirements of the following EC directive R&TTE 6/3/EG:

»Directive 1999/5/EC of the European Parliament and of the Council of 9 March 1999 on radio equipment and telecommunications terminal equipment and the mutual recognition of their conformity«.

You can also request this EC declaration of conformity at the following Internet URL: <http://www.bintec-elmeg.com>.



The waste container symbol with the "X" through it on the device indicates that the device must be disposed of separately from normal domestic waste at an appropriate waste disposal facility at the end of its useful service life..

© bintec elmeg GmbH - All rights reserved.

Reprinting of this document, even excerpts, is permitted only with the express consent of the publisher and with precise source information, regardless of the media used (mechanical or electronic).

Function descriptions included in this documentation which refer to software products of other manufacturers are based on the software used and valid at the date the documentation was prepared or published. The product and company names used in this documentation may be protected by trademarks.

Table of contents

| | |
|--|----|
| Installation | 1 |
| Terminals | 1 |
| RJ45 connector | 1 |
| Connecting leads | 1 |
| Line types for firm cabling | 1 |
| Installation-grade cable | 1 |
| Fastening of the connecting lines | 3 |
| ISDN bus with IAE jacks | 5 |
| ISDN-bus with RJ45-jacks (UAE) | 6 |
| Terminating resistors | 7 |
| Piercing connecting terminals | 7 |
| PABX terminals | 8 |
| Connecting analog terminals | 8 |
| USB port | 9 |
| Connecting options for PABX systems | 10 |
| Internal ISDN connection | 10 |
| USB port | 13 |
| General Information about USB (specification 1.1) | 13 |
| Connecting the PABX via USB to the PC | 13 |
| Index | 16 |

Installation

In this chapter, all PABX system ports are described regardless of the expansion of your PABX. The actual expansion will be described on the special pages for the respective PABX.

Terminals

Terminals can be removed from the pins of the cable terminal bay.

Hinweis

In all work on the PABX system ports, you must first turn off the PABX electricity supply and put the external system ports out of operation!!

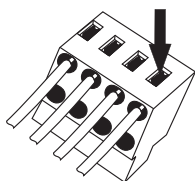

These terminals are for use with ISDN and analog connections. 2 wires can be connected to every connection. Wire diameters can range from 0.4 to 0.8 mm. The wire end to be inserted must be stripped of 6 to 7 mm of its insulation. The wires can be removed if pressure is applied with a screwdriver to the terminal bay area designated with an arrow and the wires are removed by pulling lightly.

RJ45 connector

Hinweis

The RJ45 connectors are locked after being plugged into the ISDN jack to prevent them from being pulled out. The lever points up after being plugged into the PABX.

Plug the RJ45 connector into the ISDN jack until you hear an audible »Click«, indicating that it is securely locked in.

To unlock press on the small lever on the RJ45 connector while pulling the connector out.

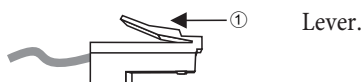

Connecting leads

For the function of the PABX terminal devices, the installation lines are very important. Operational safety, disruption sensitivity and range are dependent upon the type of line and how it is laid. Please only use the prescribed types of lines and comply with the manufacturer's installation instructions for the jacks. To the extent that such is possible, you should use the connecting cord supplied. The lines for the PABX connections may not be laid out in the open as this represents a power overload danger as can occur during thunderstorms.

Line types for firm cabling

Installation-grade cable

This cable is sold in two-pair (4-wire) and multi-pair models. Both cables can be used shielded or unshielded. For the connection, one (analog connection or UP0-connection) or two cable pairs (ISDN connection) must always be connected. The cable pairs are »twisted« together

or combined as »star-fours«. The individual designations of the wires are firmly allocated to wire defined designations. You must comply with this allocation without exception.

Hinweis

Never use the additional shielding wire as an earth line.

The lines are designated as follows:

J-Y(St) Y2x2x0,4: Installation line with plastic insulation, two pairs of wires with a copper cross-section of 0.4 square millimeters per wire. This line is also shielded and available with a copper cross-section of 0.6 square millimeters per wire. Additionally, the line is also available with more than 2 wire pairs.

Both wires of a pair are »twisted«.

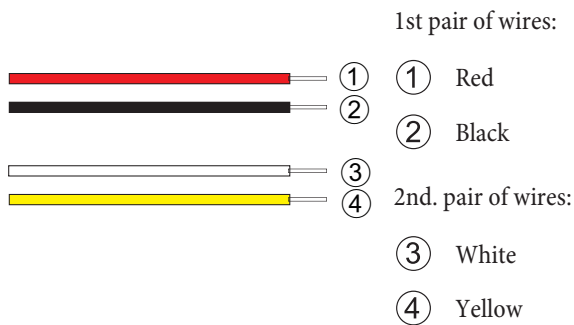

J-YY 2x2x0,6: The four wires are stranded as »star fours«.

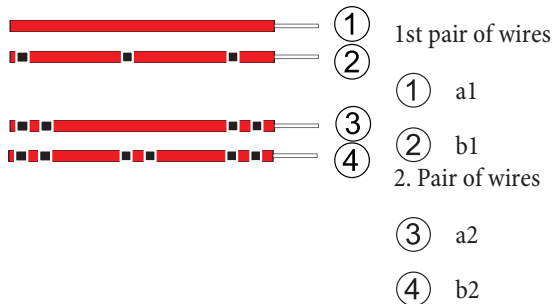

J-YY 0.6 designation, black rings on same colored wires (red, green, gray, yellow or white).

Cat. 5 cable

These lines are primarily used in PC network technology. With a corresponding connection, two ISDN connections can be installed over one line. In this process, the 1st and 2nd as well as the 3rd and 4th wire pairs are allocated to an ISDN port. Additionally, several analog connections can be installed, each pair-wise, via this line. The picture shows the connection of the CAT. 5 cable to the various jacks and the allocation of the wire pairs to the installation cable.

1 T568A:

- ① white/green
- ② green
- ③ white/orange
- ④ blue
- ⑤ white/blue
- ⑥ orange
- ⑦ white/brown
- ⑧ brown

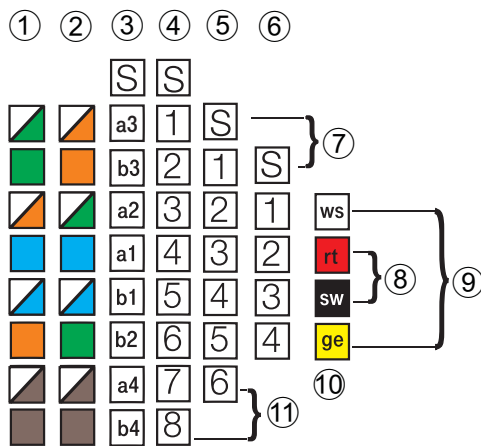

2 T568B:

- ① white/orange
- ② orange
- ③ white/green
- ④ blue
- ⑤ white/blue
- ⑥ green
- ⑦ white/brown
- ⑧ brown

3 Wire designations.

- ④ Terminal designations for the UAE8 jack.
- ⑤ Terminal designations for UAE6 jacks.
- ⑥ Terminal designations for UAE4 jacks.
- S Shielding (if available).
- ⑦ 3. pair
- ⑧ 1. st pair (analog connections a/b).
- ⑨ 2. pair.
- ⑩ Wire color for telephone cables J-Y(St)Y2x2x0,6Lg.
- ⑪ 4. pair.

This table shows the different types of connections at an RJ45 or CAT. 5 jack.

| Access | Double wire designations | analog | | ISDN | | | LAN |
|--------|--------------------------|--------|--------|------|-----|-----|--------------|
| | | 2-wire | 4-wire | S0 | UP0 | S2m | 802.310BaseT |
| 1 | 3a | | | | | | T+ |
| 2 | 3b | | | | | | T- |
| 3 | 2a | | c | R+ | | | R+ |
| 4 | 1a | a | a | T+ | a | | |
| 5 | 1b | b | b | T- | b | | |
| 6 | 2b | | d | R- | | | R- |
| 7 | 4a | | | | | | |
| 8 | 4b | | | | | | |

Fastening of the connecting lines

Ensure that no more than 100 mm of the sheathing is removed from the lines and that the stranded or twisted wires are led to the terminal bays. The wire ends must be stripped of ca. 7mm of their insulation prior to attachment. Ensure during stripping of the insulation that the copper wires are not damaged or notched.

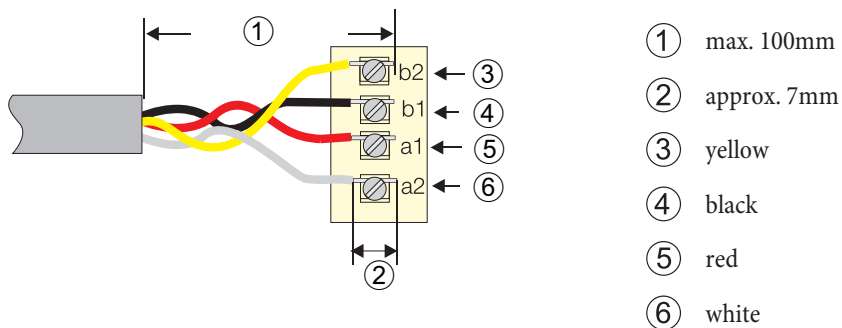

ISDN bus with IAE jacks

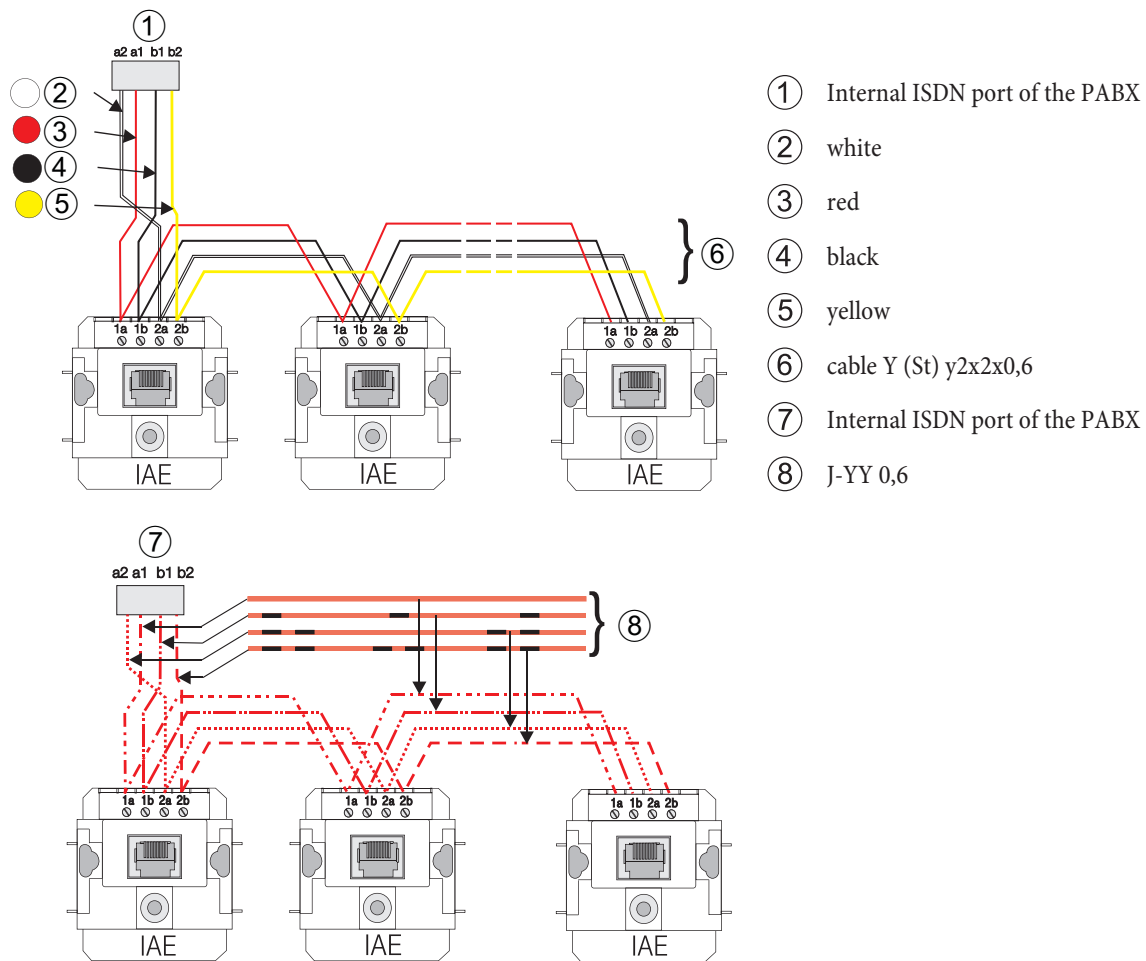

Hinweis

Please mind the terminating resistors in the last jack.

ISDN-bus with RJ45-jacks (UAE)

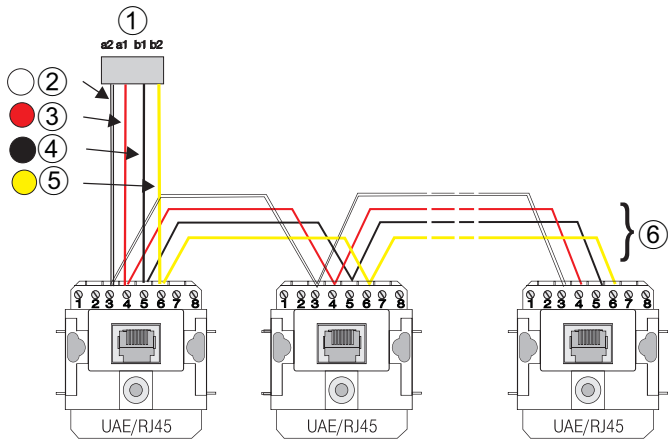

- ① Internal ISDN port of the PABX
- ② white
- ③ red
- ④ black
- ⑤ yellow
- ⑥ cable Y (St) y2x2x00.6
- ⑦ Internal ISDN port of the PABX
- ⑧ J-YY 0,6

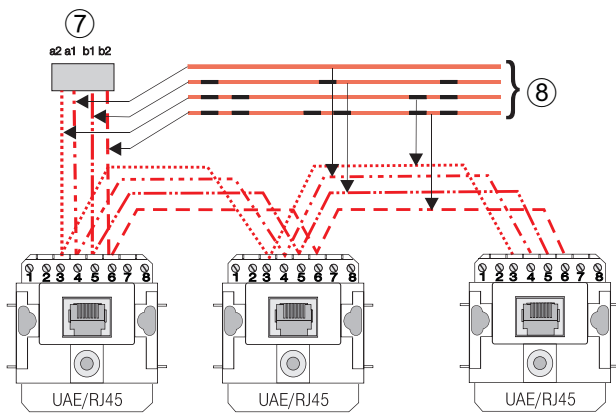

Hinweis

Please mind the terminating resistors in the last jack.

Terminating resistors

Hinweis

The terminating resistors on the cable terminal bay of the PABX are active when the switch is set to »ON«.

When connecting PABXs, modules and jacks, check whether the terminating resistors are fixed, switchable or installed at all. Read the sheets enclosed in the module packaging.

With the terminating resistors, an ISDN bus (point to multi-point) or a point to point connection is made on both sides. In this process, the a and b wires of both pairs of wires over 100 Ohm resistors are connected to one another. As resistors, 100 Ohm resistors 0.25 Watts are suitable. They are connected with the line wires as depicted in the picture. Ready-to-use terminating resistors or ISDN adapters with integrated terminating resistors are available in stores.

Hinweis

Terminating resistors must always be installed in both pairs of wires.

Please note the different connections for the terminating resistors at RJ45 (UAE) and IAE jacks!

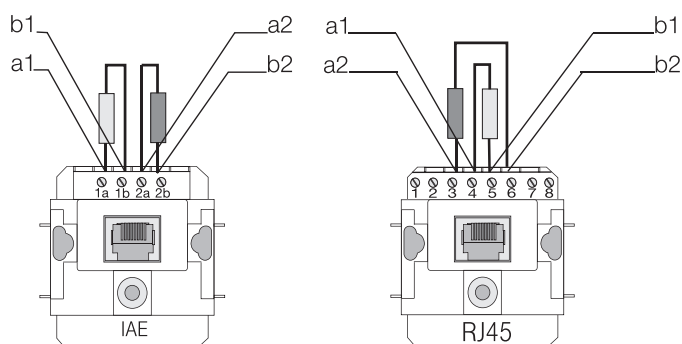

Piercing connecting terminals

You can also use an additional terminal patch (subdistribution or patch panel (e. g. LSA Plus strip) between the PABX system and the ISDN jacks of your installation. With conventional terminals the insulation of the installation cable is removed and the cable clamped or screwed securely beneath the connecting strip. With piercing terminals you do not have to remove the insulation from the cable, as the terminals pierce or cut through the insulation and establish contact with the cable. When using piercing terminals, you will require a special installation tool.

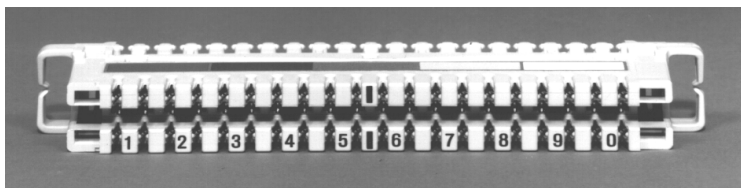

Please note here that you can only connect one installation cable in each LSA Plus insulation piercing terminal, as otherwise there may not be proper contact of the wire.

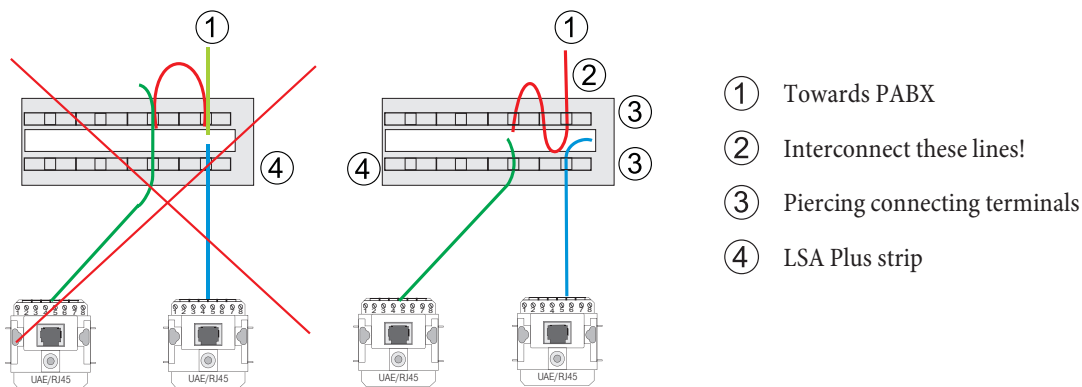

PABX terminals

Hinweis

Always switch off the power supply before working on the cable terminal bay!

Hinweis

Attention! Switching the external and internal ISDN ports is carried out exclusively through configuration. You should check before switching the ports, that no external supply is connected to them. The PABX output or the network termination unit could otherwise be damaged!

The external and internal ISDN connections are routed to an 8-pin RJ45 jack (Western jack). The catch on the ISDN connector points up. The four middle pin connections (3,4,5,6) of the RJ45 jack are connected. Hardwiring terminals are provided for internal connection. You can also use »star-type wiring« for installing the PABX systems. For this, you can deactivate the internal terminators.

Connecting analog terminals

Analog terminals are, for example, telephones, multifunctional devices, fax machines of group 2/3 and call answering machines which can be connected to the conventional telephone network or to analog PABX systems. The calling method used for these terminals can be either pulse (PD) or multifrequency (DTMF). The PABX supports both these dialing methods. However, certain functions of the PABX can only be used via the Flash function of the terminal devices. This Flash function is only possible with DTMF dialing. The analog terminal devices are connected via 2-wires; the connections on the terminals are designated with »a« and »b«. The connection of each terminal device must always take place via one pair of wires.

International

Connection with RJ-jacks:

RJ11. The jack has 4 contacts (2...5). Connection takes place to the terminals with the designation 3 (a-wire) and 4 (b-wire). The connector of the connection cables has 6 contacts.

RJ12. This jack has 6 contacts (1...6). Connection takes place to the terminals with the designation 3 (a-wire) and 4 (b-wire). The connector of the connection cables has 6 contacts.

RJ45. This jack has 8 contacts (1...8). Connection takes place to the terminals with the designation 4 (a-wire) and 5 (b-wire). The connector of the connection cable has 8 contacts.

When selecting jacks, please check whether the connector of the connection cable for your terminal device has 6 or 8 contacts.

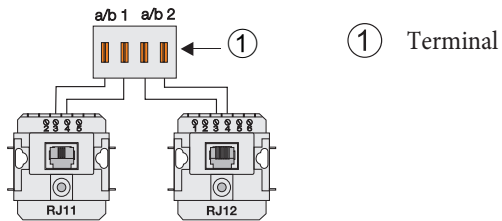

Germany

Analog terminal devices are connected using TAE-jacks.

Note that when using telephones, TAE jacks with code »F« for additional devices, such as Fax group 2/3 TAE jacks with the code »N« must be used. Ask your dealer about the coding for the connections when purchasing any jacks.

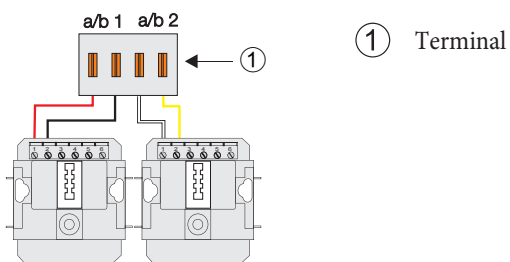

Austria

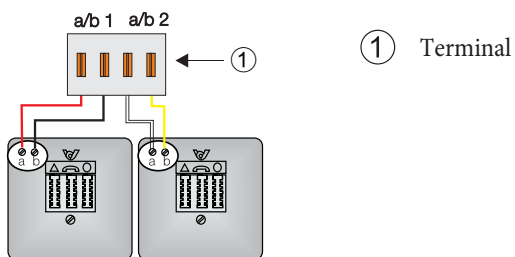

Switzerland

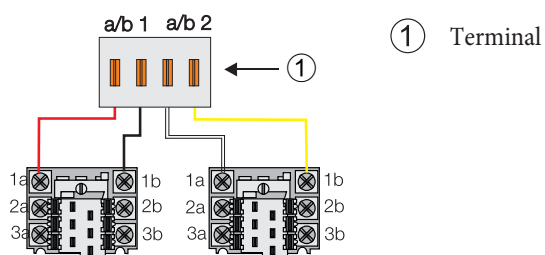

France

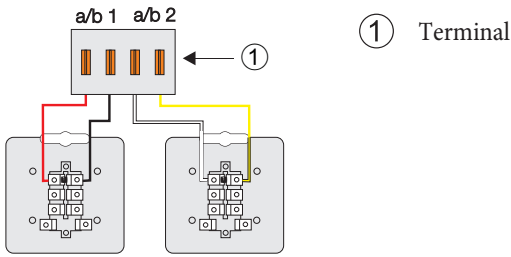

USB port

The PABX system is a full-speed USB terminal device with rates up to 12 MBit/s. Power is supplied to the USB port via the PABX system. The PABX system is a self-powered, category 1.1 full-speed terminal device

Connecting options for PABX systems

Connecting the PABX to the ISDN network of the network service provider

The following figures illustrate the connecting options for the PABX to the external ISDN connection.

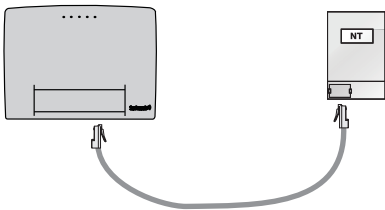

Direct ISDN connection using the ISDN connecting cord supplied with the system at the network termination (NT). This connection option is possible with point-to-point and point-to-multipoint connections. The switches for the terminators in the PABX system must be closed.

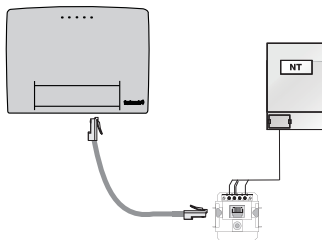

Connection to an ISDN jack installed downstream of the network termination. This connection option is possible with point-to-point and point-to-multipoint connections. Ensure proper connection of the terminating resistors in the PABX, the network termination and the jack.

Internal ISDN connection

»Short passive bus«

The internal ISDN connection of the pabx is set as a »Short passive bus«. The »short passive bus« has a length of 120 meters. Up to 12 ISDN jacks may be connected in series. You can connect up to 8 terminal devices. Combined, internal terminal devices may have a maximum consumption of up to 2 W. Other terminal devices on the bus must have external power supply (with their own power supply units). Two of the ISDN terminal devices can be in operation simultaneously (e.g., you can use two phones to telephone internally or externally simultaneously using one bus). The 100 ohms terminating resistors must be connected to the last ISDN jack installed on the ISDN bus.

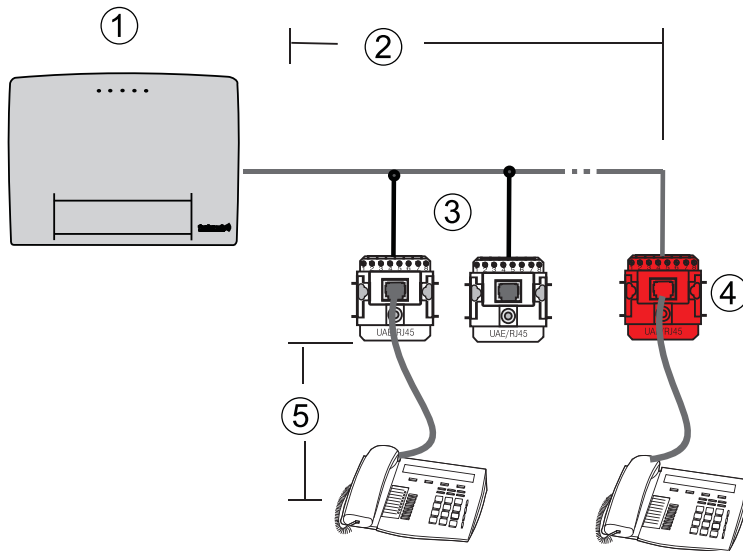

- ① PABX with active terminating resistors.
- ② Bus length: See connecting lines.
- ③ A maximum of 12 ISDN jacks on the bus.
- ④ Terminating resistors in the last ISDN jack.
- ⑤ A maximum of 8 ISDN terminal devices can be used. Connection cables for the terminal devices, max. 10 meters.

»Short passive bus«: Star-type wiring (structured wiring)

Star-type wiring is a special version of the »short passive bus«. Here, you can use the existing 4-wire installation for connecting ISDN terminal devices to an internal ISDN bus. Depending on the cables used, the distance between the two ISDN jacks for a star-type wiring configuration may not be greater than 120 m (up to 180 meters with CAT. 5 cables). Connect only one ISDN jack (also with 2 RJ45 jacks) to the two ends of the ISDN bus and plug the ISDN terminal devices directly into the jack.

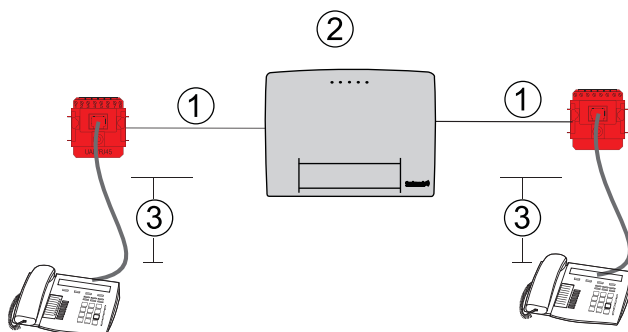

- ① Right and left branch of a star-type wiring.
- ② PABX.
- ③ One ISDN terminal device only can be used. Connection cables for the terminal devices, max. 10 meters.

The branches of a star-type wiring are longer than 10 meters:

- Terminating resistors must be fitted to the jacks at both ends. The terminating resistors in the PABX system for the corresponding connection must be opened.

The branches of a star-type wiring are shorter than 10 meters:

- No terminating resistors required for the jacks at both ends. The switches for the terminators in the PABX system must then be closed.

»Short passive bus«: Star-shaped structured wiring

Structured wiring based on the existing installation in the building using 8-wire installation cable routed in a star shape from a central point. In order to use several terminal devices at one ISDN connection, this configuration should run as a bus from terminal to terminal. To take full advantage of the 8-wire building installation configuration, 4 wires are connected to each terminal device as feed lines and 4 as return lines. In this manner, a star-type ISDN bus is created. Coupling of the 4 forward and 4 return cores can be effected in the ISDN jack, or via a star adapter that can be plugged into the ISDN jack. The terminating resistors are either installed in the last ISDN jack or integrated into the ISDN star router. Since this installation also represents a »short passive bus«, the maximum total length may not exceed 120 meters (including forward and return lines from the distribution point to the jack).

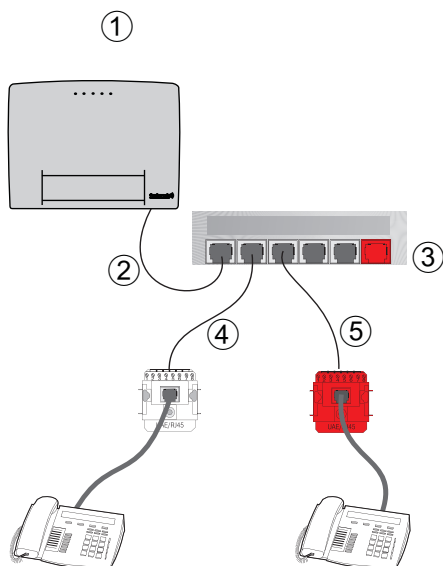

- ① PABX with active terminating resistors.
- ② Connection of the hub to the PABX (4-wire).
- ③ ISDN hub.
- ④ 8-wire line: 4 wires for the feed line and 4 for the return line.
- ⑤ Terminating resistors in the last ISDN jack.

Some companies offer star routers with various expansion stages. Ensure that you observe any special features in the operating instructions of these devices.

USB port

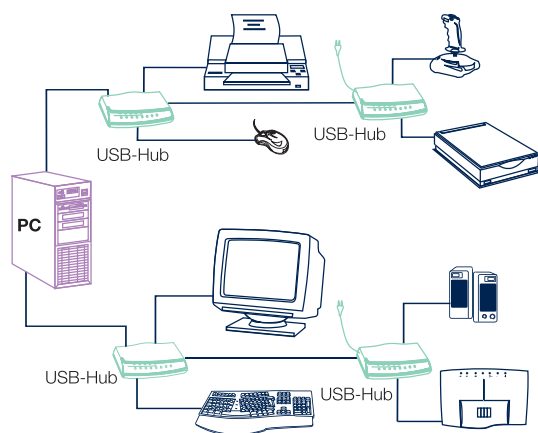

General Information about USB (specification 1.1)

USB is the abbreviation for Universal Serial Bus. USB is a serial bus system that allows you to operate various types of devices at one port. This interface can supplement or replace various PC ports (serial, parallel, . . .) devices at one port.

USB is equipped with a standardized API (Application Programming Interface) that is based on the Microsoft Win32 driver model (WDM).

In the past, if you wished to operate a new device on the standard ports of your PC, installation (unscrew PC, open it, insert card) and configuration procedures (set interrupts and addresses and eliminate any conflicts) were often difficult or complicated. To put a USB terminal device into operation all you have to do is plug it in to the USB port. The configuration of the terminal device is carried out automatically by Plug&Play-compatible operating system (for example Windows 98, ME, 2000). You then only have to insert the disk or CD containing the drivers for your device and install the appropriate drivers. You only need to restart your PC on the initial startup of the USB terminal device.

With a Plug&Play operating system you can also unplug the connector of an installed terminal device from the USB and plug it back in while the PC is running. You do not need to restart your PC after this. The operating system automatically recognizes the terminal device that has been plugged in and then loads the required drivers.

A standard connector and cabling system allows you to connect any type of terminal devices (such as keyboard, mouse, printer, scanner etc.) A distinction is made here between type A- and type B plugs. The different architecture of these connectors means that you can not confuse them. When installing a USB terminal device, plug Type A is connected to the sending device (your PC or a hub) and plug Type B into the receiving device (printer, scanner, telephone, etc.).

Connecting the PABX via USB to the PC

Connect the PABX to the USB port of your PC as shown in the figure. Use the USB cable supplied with the system.

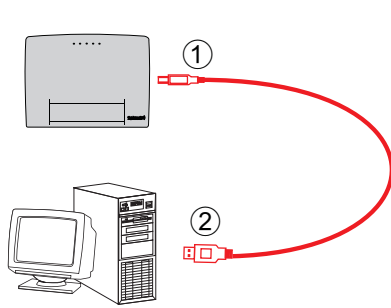

① USB connector (type B terminal device)

② USB connector (type A PC/hub)

You require a USB hub (USB distributor) if you wish to use several USB terminal devices at your PC. Connect the hub to the USB port of the PC. You can then connect other USB terminal devices, including the PABX, to the hub. Use the USB cable supplied with the system.

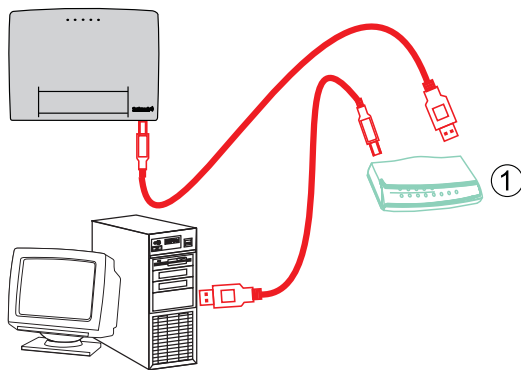

① USB-Hub

Hinweis

Use the USB cord supplied with the system to connect the pabx to the PC, or to the hub. If you use a different USB cord, ensure that the distance between the pabx and the PC, or between the pabx and the hub, does not exceed five meters, depending on the type of cord you are using.

USB cables

| | |
|------------|---|
| Full Speed | Data line: Twisted pair (min. 28 AWG) shielded Power supply: non-twisted pair (min. AWG 28), also for shielding Maximum length 5 meters Connector: A and B connector |
| Low speed | Lines: 4 wires (min. AWG28). 2 each for power supply and data lines Maximum length. 3 meters Line always fixed to the device Connector: A connector at the free end |

Cable length and type

| Line delay 30ns | | | |
|------------------------|------------------------|-----------------------|--------|
| AWG | Resistance (Ohm/meter) | max. length in meters | |
| 28 | 0,232 | 0,81 | |
| 26 | 0,145 | 1,31 | |
| 24 | 0,091 | 2,08 | |
| 22 | 0,057 | 3,33 | |
| 20 | 0,036 | 5,00 | |
| Colors | | | |
| VCC | Data+ | Data- | Ground |
| red | green | white | black |

Index

A

| | |
|-----------------------------------|---|
| Analog terminal devices | 8 |
| Austria | 9 |
| France | 9 |
| Germany | 8 |
| international | 8 |
| Switzerland | 9 |

C

| | |
|---|-------|
| Cat. 5 cable | 2 |
| Connecting leads | 1 |
| Connecting the PABX via USB to the PC | 13-15 |
| Connections of the PABX | 8 |

F

| | |
|--|-----|
| Fastening of the connecting lines. | 3-4 |
|--|-----|

I

| | |
|--------------------------------------|-------|
| IAE jacks | 5 |
| Installation | 1-15 |
| Installation-grade cable | 1-2 |
| Internal ISDN connection | 10-12 |
| ISDN terminating resistors | 1 |

J

| | |
|----------------------------|-----|
| J-Y(St) Y2x2x0,4 | 2 |
| J-YY 0,6 | 2,5 |

L

| | |
|--------------------------|---|
| Line types | 1 |
| LSA Plus strip | 7 |

N

| | |
|------------------|----|
| NT / NT. | 10 |
|------------------|----|

P

| | |
|---|----|
| Piercing connecting terminals connections | 7 |
| Plug-and-Play (USB) | 13 |

R

| | |
|--------------------------|---|
| RJ45 connector | 1 |
| RJ45-jacks | 6 |

S

| | |
|-----------------------------|----|
| Short passive bus | 10 |
| Star-type wiring | 10 |
| Structured wiring | 10 |

T

| | |
|----------------------------------|----|
| TAE jacks | 9 |
| TAE-jacks | 8 |
| Terminals | 1 |
| Terminating resistors | 7 |
| Type A connector (USB) | 13 |
| Type B connector (USB) | 13 |

U

| | |
|--|------|
| UP0 connection | 9 |
| USB | |
| connector (type A / type B) | 13 |
| USB cable | 3 |
| USB cables | 15 |
| USB connector (type A PC/hub). | 13 |
| USB connector (type B terminal device) | 13 |
| USB port | 9,13 |
| USB specification 1.1 | 13 |
| USB-Hub | 14 |

Y

| | |
|---------------------------|-----|
| Y (St) y2x2x0,6 | 5-6 |
|---------------------------|-----|

bintec elmeg GmbH
Südwestpark 94
D-90449 Nürnberg

For information on support and service offerings please visit our Website at
www.bintec-elmeg.com where, you will find a Service / Support area

Subject to modifications
Ausgabe 6 / 20131218